

Tri-Flo Int'l, Inc.

P.O. Box 2626, Conroe, Texas 77305
Bus: (936) 856-8551 Fax: (936) 856-5668

SERVICE & OPERATING MANUAL

113 SHALE SHAKER



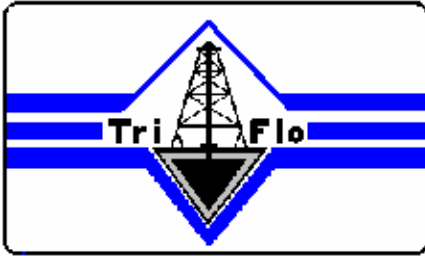

Tri-Flo Int'l, Inc.

P.O. Box 2626, Conroe, Texas 77305
Bus: (936) 856-8551 Fax: (936) 856-5668

TRI-FLO 113 HIGH SPEED SHALE SHAKER

	Page
General Information	3
Operation	4
Location	5
Flow line	5
Shale Slide	5
Power Requirements	6
Screens	7
Lubrication	8
Adjustments	8
Vibrator Rotation	8
Inspection	9
Disassembly of the Vibrator	10
Assembly of the Vibrator	11
Changing Vibrating Deck Springs	12
Troubleshooting	
Electric Motor	13
Vibrating Mechanism	13
Screen Life	14
Spare Parts	15
Safety	15
Tightening Torques	16
Forces	16
Recommended Lubricants	16
Screen Sizes	17
Wiring Diagram (Voltage Changes)	18
Table for Oilfield Shakers	19
Tension Plate and Screen Assembly	20
Shaker Vibrator Housing, Chart	21
Drawing of Vibrator Housing	22
Parts Breakdown	23
Notes	25

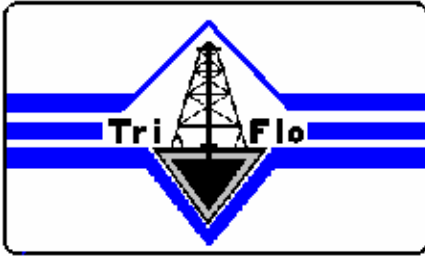

Tri-Flo Int'l, Inc.

P.O. Box 2626, Conroe, Texas 77305
Bus: (936) 856-8551 Fax: (936) 856-5668

INTRODUCTION

GENERAL INFORMATION

The TRI-FLO 113 SHALE SHAKER is a compact and reliable solids removal method. Most shakers are similar in design and application. TRI-FLO asserts that their high-speed shale shaker is that necessary first line of defense against large drilled solids reentering an active mud system. The TRI-FLO 113 SHALE SHAKER easily removes 74 micron, or larger size, particles for proper mud weight maintenance and efficient solids control. Balanced mud rheology leads to longer pump life, less daily fluid maintenance expense, improved desander and desilter efficiency, and better penetration rates.

TRI-FLO 113 SHALE SHAKER is mounted on a heavy-duty skid for added strength and stability. The screen box and deck are made of low alloy steel, reinforced with heavy pipe.

Vibrator amplitude may be changed to six different positions in 1/8" increments. The adjustment is made by changing the position of the unbalanced weights in relation to the eccentric shaft. IT IS IMPORTANT THAT BOTH WEIGHTS BE ON THE SAME SETTING. The vibrator assembly can be changed in the field quickly and simply.

The lower skid base contains the possum belly with the mud inlet at the bottom and the mud flume at the top.

Replacement screens are available from coarse 10-mesh variety to a 400 mesh fine screen and they are easily changed in the field.

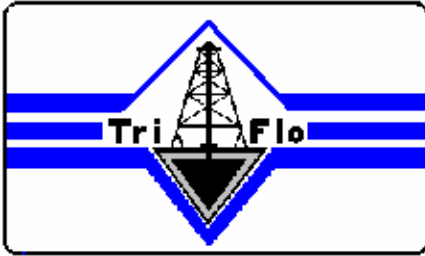

Tri-Flo Int'l, Inc.

P.O. Box 2626, Conroe, Texas 77305
Bus: (936) 856-8551 Fax: (936) 856-5668

OPERATION

The TRI-FLO 113 SHALE SHAKER is installed on the end of the mud tank and has a mud line attached to the possum belly from the rig. The drilling mud flows down the line into the possum belly, through the diverter vanes on the mud flume, onto the screens. After the mud passes through the screens it travels through the mud outlet located on the side, into the mud tank. The drill solids or cuttings remain on the screen and then fall off the back of the TRI-FLO 113 SHALE SHAKER.

The vibrator shaft is driven at 1750 RPM by a 2 HP motor.

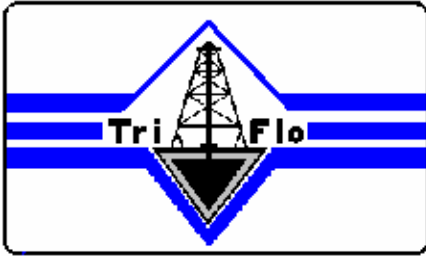

Tri-Flo Int'l, Inc.

P.O. Box 2626, Conroe, Texas 77305
Bus: (936) 856-8551 Fax: (936) 856-5668

INSTALLATION

LOCATION

The TRI-FLO 113 SHALE SHAKER should be mounted at the end of the tank. The TRI-FLO 113 SHALE SHAKER should be mounted with the inlet towards the flow line and the skid secured to the mud tank.

It is important that the TRI-FLO 113 SHALE SHAKER be mounted level. This will aid in an efficient operation.

After mounting remove the **four** shipping bolts. These bolts are located at each spring coil on the vibrating deck.

FLOWLINE

Connect a flow line between the bell nipple and the mud inlet of the TRI-FLO 113 SHALE SHAKER.

It is not recommended to run the flow line into the top of the possum belly, as it will reduce the volume of the mud the screens can handle.

SHALE SLIDE

If it is not desirable to permit the cuttings or solids to drop off the end of the screen, it will be necessary to construct a shale slide from the end of the TRI-FLO SHALE SHAKER to the shale pit. This slide should be as steep as possible. Water spray may be added to wash the cuttings into the shale pit.

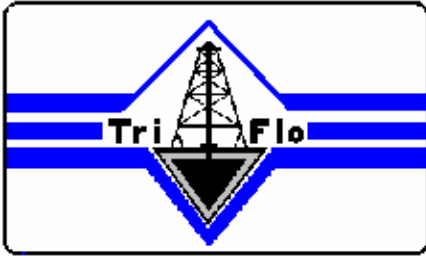

Tri-Flo Int'l, Inc.

P.O. Box 2626, Conroe, Texas 77305
Bus: (936) 856-8551 Fax: (936) 856-5668

POWER REQUIREMENTS

Connect the power cable from the motor starter switch to the rig power supply. Connect the green insulated wire to ground.

The TRI-FLO 113 SHALE SHAKER is normally wired at the factory for 480 V.A.C., 60 HZ, 3 PHASE.

If 220 V.A.C., 60 HZ, 3 PHASE is needed it is necessary to:

1. Rewire the motor. (See motor wiring diagram on Page 18)
2. Change the heater strips on the motor starter switch.
3. The motor junction box must be packed with foam rubber to prevent the wires from rubbing together when the shaker is vibrating. This is necessary after the rewiring is completed.

Turn the starter switch on and check the motor rotation. The top of the belt should travel in the same direction as the flow of the mud.

This is from the front of the shaker to the back.

If the rotation is incorrect, change any two of the red, black or white wires at the motor junction box at the rig power supply. The green wire should always be ground and would not effect the rotation of the motor.

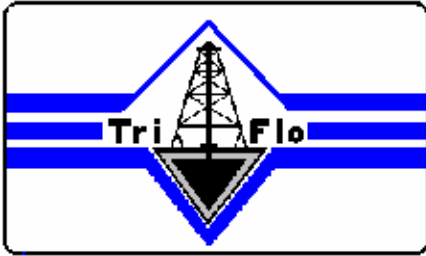

Tri-Flo Int'l, Inc.

P.O. Box 2626, Conroe, Texas 77305
Bus: (936) 856-8551 Fax: (936) 856-5668

SCREENS

The procedure to install or change the screens is as follows:

1. Remove the tension lock nuts, washers, tension springs, the tension bolts and the tension rail plates from the screen box. (See tension plate detail on Page 20) on the screen support bars.
2. Install decking rubber (Item 23 on Page 20) on the screen support bars.
3. Install the screen in position, leaving equal space on each side. When installing the screen be careful not to bend or crease these screens.
4. Put the tension plates in position with the bolts extending through their respective holes in the side plates of the screen box. The tension rail plates should only touch the hook strips and not the screen.
5. Install the springs, washers and lock nuts. Tighten the tension lock nuts to expose 1/8" of the threads, starting at the center tension lock nuts and working toward each end.
6. Check the screen for creases and ripples. If any appear, the hook strips are not even. Work out the wrinkles by hand by adjusting the position of the hook strips and by smoothing the screen cloth by hand.
7. Tighten the center tension lock nuts to expose 5/8" of threads, and then tighten the other nuts the same amount, working from one side and the other.
8. Tighten the nuts just enough to fully compress the tension springs. Rap the tension plate and the tension bolt heads lightly with a hammer to insure that the bottom of the tension plate is parallel to the support bar. After fully compressing the springs they will maintain tension on the screens. It is recommended that after 3 hours the tension nuts should be retightened.
9. Wet the screen with water (or diesel when using oil mud) before diverting mudflow over the screen.

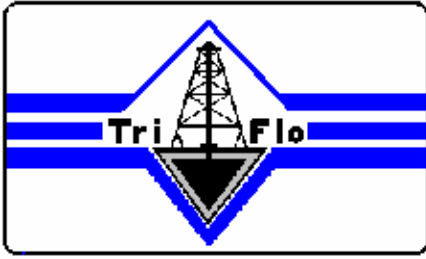

Tri-Flo Int'l, Inc.

P.O. Box 2626, Conroe, Texas 77305
Bus: (936) 856-8551 Fax: (936) 856-5668

LUBRICATION

TRI-FLO recommends that the grease fillings located on top of each cartridge be greased every twelve hours. Normal service requires approximately 1/2 ounce of grease in each bearing each 12 hours.

See Page 16 for recommended bearing lubricants.

ADJUSTMENTS

The intensity of vibrations may be varied to suit conditions by changing the position of the adjustable counterweights. Position 1 gives the maximum, and each successive notch or setting reduces the motion. Position 6 gives the minimum intensity of vibrations. IT IS IMPORTANT THAT BOTH COUNTERWEIGHTS HAVE THE SAME SETTING. This is easily checked by the alignment on the notches in the counterweights.

VIBRATOR ROTATION

The direction of rotation is normally with the flow of the material. In some situations, for a different retention time, the rotation can be opposite the flow of the material (counter flow). Changing from one to the other is done by reversing the electrical leads to the motor.

Other factors such as screen incline and vibrator speed may be adjusted under some circumstances, under the guidance and direction of TRI-FLO INDUSTRIES INTERNATIONAL, INC.

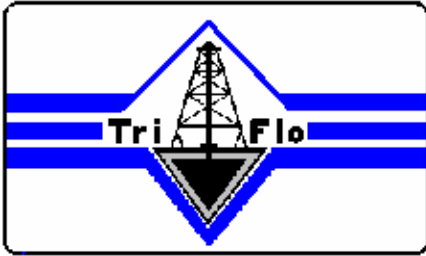

Tri-Flo Int'l, Inc.

P.O. Box 2626, Conroe, Texas 77305
Bus: (936) 856-8551 Fax: (936) 856-5668

MAINTENANCE

INSPECTION

A regular schedule of complete dismantling, inspection, and relubrication intervals assures maximum screen life and minimum downtime. The customer should keep a complete record of all such preventive maintenance plus a record of any repairs. Since the TRI-FLO SHALE SHAKER is a vibratory machine, it is important to correct all minor troubles before serious damage develops. Replace faulty support springs and any missing bolts at once. Cracks forming in the structure (usually at or near the joints) and unusual noises and motion are signs of developing failure. Drill 1/4" holes through the ends of such cracks and consult TRI-FLO at once in the event of such failures. **WARNING IF WELDING IS DONE TO NO GROUND WELDER THRU VIBRATING SCREEN.**

After 1500 to 2000 hours of operation, dismantle the vibrator mechanism and clean all parts. Flush bearings with a 200° light transformer, or automotive flushing oil. Check screen tension periodically. On reassembly, pack the bearings with grease and also fill the adjacent cavity in the housing and retainer with grease to the bottom of the shaft.

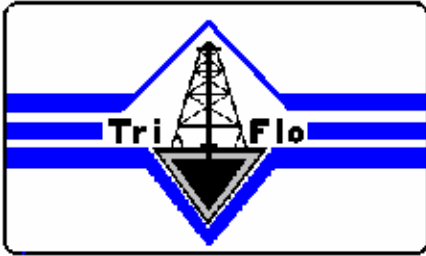

Tri-Flo Int'l, Inc.

P.O. Box 2626, Conroe, Texas 77305
Bus: (936) 856-8551 Fax: (936) 856-5668

DISASSEMBLY OF THE VIBRATOR

WARNING: DISCONNECT POWER TO THE ELECTRIC MOTOR AND LOCK THE DISCONNECT SWITCH IN THE OPEN POSITION.

1. Remove motor and drive pulley guard.
2. Remove the counterweight guard from both ends of the vibrator shaft.
3. Loosen the four motor support bolts located under the motor, loosen the V-belts and remove them.
4. Remove the V-belt sheave (Item W, Page 22), by first loosening its taper lock hub.
5. Remove the counterweights (Item R, Page 22), by removing the clamp screws and reusing the screw to open the slots in the counterweights, by tightening the screws into the tapped holes.
6. Remove the collars (Item G, Page 22) and the retainers (Item C) with the Spiro lox rings (Item D) in their grooves. Remove cartridge cap screws (Item U).
7. Remove retaining ring (Item K) from the drive side only. By striking on one end of the shaft (Item B) with a lead hammer or a hammer and a block of hardwood, it is possible to start to drive out the cartridge (Item T) on the other side.
8. Then it should be easy to pry either or both cartridges loose from their bores in the housing ends. If difficulty is experienced a cartridge can be bumped from the inside by striking the shaft again at the other end. When one cartridge is removed the shaft can be slipped from the housing.
9. The bearing remaining in the other cartridge should be removed by using 3 long 3/8" NC cap screws and pushing the bearing out. Before inserting the cap screws, the setscrews must be removed.

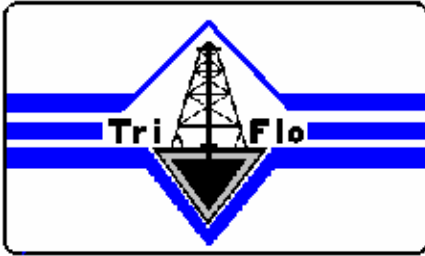

Tri-Flo Int'l, Inc.

P.O. Box 2626, Conroe, Texas 77305
Bus: (936) 856-8551 Fax: (936) 856-5668

REASSEMBLY OF THE VIBRATOR

1. Be sure the housing, cartridges, bearings, shafts, etc. are clean. Flush the bearing with (200° F) light transformer, spindle, or automotive flushing oil; DO NOT USE KEROSENE OR GASOLINE.
2. Make a sub-assembly of the bearing, cartridges, Spiro lox rings (Item E, Page 22), and the setscrews (Item L). The latter must be replaced in the cartridges as in the original assembly if they have been removed to use longer cap screws for bearing removal.
3. Position and secure on such cartridge-bearing sub-assembly in the housing end on the drive side. Slide the shaft thru the housing from the other side and slip it through the bearing bore. Rotate the shaft while installing the Spiro lox rings (Item E). Secure the shaft axially to the drive side bearing by forcing the retaining ring (Item K) into its groove in the shaft.
4. Slip the other cartridge-bearing sub-assembly over the shaft on the side opposite the drive end. Push and tap it into position in the housing end, lifting on the shaft end to center all components properly. Secure cartridges with cap screws (Item U) and lock washers (Item V). See Page 16 Section for torques of the cap screws.
5. Be sure that the shaft and bearings turn freely. Pack both bearings with recommended grease. See Page 16 for recommended grease.
6. Slip Spiro lox rings (Item D, Page 22) into the retainer grooves. Pack the retainers (Item C) with grease to the bottom of the shaft. Slip over the shaft ends, push into position, and fasten with cap screws (Item R). Torque all bolts and cap screws on the vibrator assembly to specifications listed on Page 16 entitled TIGHTENING TORQUES FOR HIGH-STRENGTH BOLTING.
7. Put indexing collars (Item G & Item H) on shafts. The notched edge of these collars should face the shaft ends. Looking down on

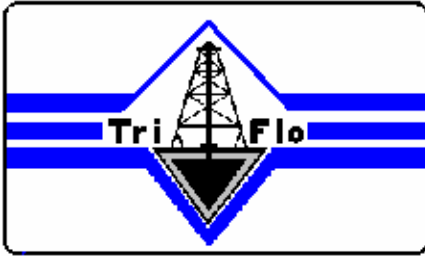

Tri-Flo Int'l, Inc.

P.O. Box 2626, Conroe, Texas 77305
Bus: (936) 856-8551 Fax: (936) 856-5668

these collars, the numbers on the indexing bands will read counter clockwise on one side and clockwise on the other side. Secure the setscrew collars over the key.

8. Mount the counterweight (Item R) on the shafts using the clamp screw in the tapped hole to open the slot to facilitate mounting. Make certain that the projecting lugs of each counterweight engage with the corresponding numbered notches in the indexing collars (Item G & Item H) to produce equal unbalancing or vibrating effects at each end of the shaft.
9. Remove the clamp screw from the tapped hole and insert into the through hole in the counterweight. Secure the counterweight by tightening the clamp screws.
10. Install the V-belt sheave (Item W) and it's Taper-Lock bushing onto the shaft by tightening the screw in the Taper-Lock bushing.
11. Install the matched set of V-belts and tighten the motor support bolts after the V-belts are adjusted. Tighten only enough to prevent slippage when starting and to prevent belt whip.
12. Install the counterweight guards and the motor pulley guard.
13. Check the bolts for fastening the vibrator housing to the screen box. These bolts should be tightened to 210 ft. lbs. See Page 14 for bolt torque.

CHANGING THE SPRING COILS ON VIBRATING DECK

The Spring Coils on the vibrating deck should be checked every 6 months. When the spring shrinks or collapses to less than 4 inches they should be replaced. A new spring measures 4-1/2 inches. This is done by lifting the shaker box, removing the old springs, and installing the new ones.

TROUBLESHOOTING

ELECTRIC MOTOR

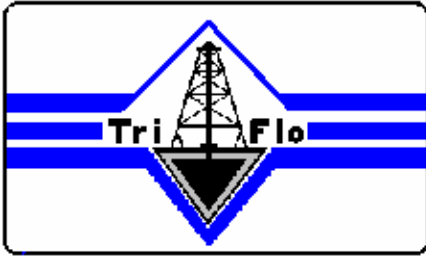

Tri-Flo Int'l, Inc.

P.O. Box 2626, Conroe, Texas 77305
Bus: (936) 856-8551 Fax: (936) 856-5668

1. Check for loose bearings.
2. Check the mounting bolts.
3. Check the belt tension.
4. Inspect the power cable for wear between the switch and the motor.

VIBRATOR MECHANISM

Overheating of the Vibrator

1. CAUSE: Too little lubricant
SOLUTION: Check seals for leakage and add lubricant.
2. CAUSE: Too much lubricant
SOLUTION: Remove lubricant until proper amount is indicated.
3. CAUSE: High ambient temperature caused by handling hot material or by surrounding condition.
SOLUTION: Ventilate area or use high temperature lubricant.

Lubricant Leakage

1. CAUSE: High temperature causes grease to become fluid and leak through the seals.
SOLUTION: Use high temperature grease.

Gritty Bearing

1. CAUSE: Entrance of grit while servicing or through the seals during operation.
SOLUTION: Flush bearing and cartridge and relubricate.

Noisy Bearing

1. CAUSE: Bearing failure caused by mentioned reasons.
SOLUTION: Replace bearings: take necessary precautionary steps to avoid reoccurring failure.

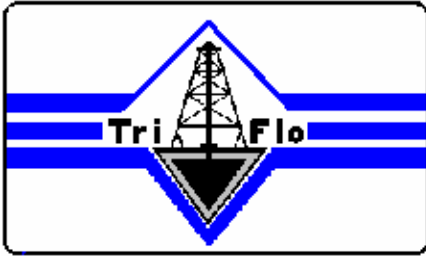

Tri-Flo Int'l, Inc.

P.O. Box 2626, Conroe, Texas 77305
Bus: (936) 856-8551 Fax: (936) 856-5668

2. CAUSE: Normal fatigue failure associated with the vibrator service-identified by spalling or roller and inner race at the high load zone.

SOLUTION: Replace the bearings; see assembly instructions.

Erratic Vibration or Performance

1. CAUSE: Slipping of the V-belts.
SOLUTION: Replace worn belts or tighten belts by adjusting the motor slide base.
2. CAUSE: Throwing of V-belts.
SOLUTION: Check belt alignment; check counter weights to insure they are on the same number.
3. CAUSE: Unit is not level
SOLUTION: Relevel the shaker with shims.

SHORT SCREEN LIFE

1. Careless handling and installation.
2. Failure to clean all support surfaces prior to screen installation.
3. Improper tension during installation.
4. Tension plates are not seated properly.
5. Cuttings build up under the edge of the screen.
6. Worn or dirty deck rubber.

SPARE PARTS

Always order spare parts from TRI-FLO INDUSTRIES INTERNATIONAL. This is particularly true of bearings, which may not be available from the local bearing sources because of special internal clearance requirements.

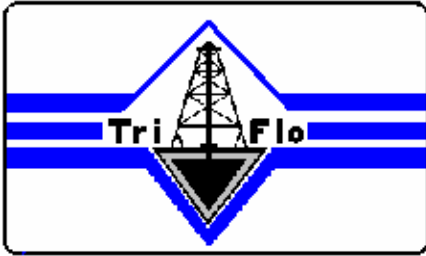

Tri-Flo Int'l, Inc.

P.O. Box 2626, Conroe, Texas 77305
 Bus: (936) 856-8551 Fax: (936) 856-5668

It is advisable to stock the following parts so that breakdowns can be repaired promptly and costly delays eliminated.

Name of Part	Quantity	TRI-FLO Part No.
Bearing	2	05-00-043
Bearing Cartridge	1	05-00-345
V-belt, B-64	2	05-00-069
Tension Bolt Assembly (includes bolts, nut, spring and 2 washers)	6	03-00-006
Spiro lox ring-retainer	4	03-00-008
Sprio lox ring-cartridge	4	03-00-009
Spring, Coil (Vibrating Deck)	4	03-00-005
Retaining ring	1	05-00-322

For screens see Page 17 Screen Sizes

SAFETY

NO PERSON SHOULD STAND, HOLD OR LEAN AGAINST THE VIBRATING FRAMES. VIBRATIONS TRANSMITTED TO THE HUMAN BODY CAN BE HARMFUL. THESE SCREENS ARE NOT THERAPEUTIC DEVICES.

BECAUSE OF THE MOTION OF THE VIBRATING SCREEN IT IS IMPOSSIBLE TO SERVICE THE SHAKER WHILE IN MOTION. NEVER LAY TOOLS OR SPARE PARTS ON THE SCREENS.

ONLY TRAINED PERSONNEL SHOULD OPERATE OR REPAIR THIS SHAKER.

TIGHTENING TORQUES FOR HIGH-STRENGTH BOLTS.

Cap screw or bolt diameter, inches	Torque foot•pounds	
	Bolts	Cap screws
3/8"	41	47
1/2"	105	120

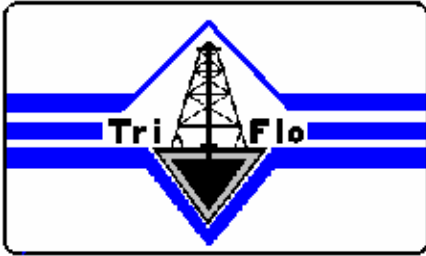

Tri-Flo Int'l, Inc.

P.O. Box 2626, Conroe, Texas 77305
 Bus: (936) 856-8551 Fax: (936) 856-5668

5/8"

210

210

FORCES

Forces generated by TRI-FLO's 113 vibration screen at various counterweight settings.

Settings (g's)	Unbalance (inch-lbs)	Stroke (inches)	Forces
1	31.0	.101	4.4
2	29.8	.097	4.2
3	26.8	.087	3.8
4	21.9	.071	3.1
5	15.4	.050	2.2
6	8.0	.026	1.1

RECOMMENDED LUBRICANTS

Shell Oil Co.	Alvania No. E P-2
Texaco Inc.	Multifax No. E P-2
Gulf Oil Co.	Crown No. 2
Chevron Oil Co.	Duralith No. E P-2
Mobil Oil Corp.	Mobilux E P-0,1,2
Universal	Mollux No. 3400
Citgo	Mystik SX-6 Extreme Temp. -65 to 350 degrees
Citgo	Mystik JT-6 High Temp.

SCREEN SIZES

MESH

TRI-FLO PART NO

10 Mesh Screen

05-00-481

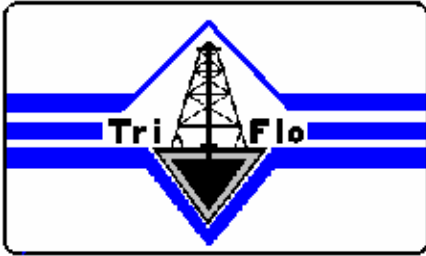

Tri-Flo Int'l, Inc.

P.O. Box 2626, Conroe, Texas 77305
Bus: (936) 856-8551 Fax: (936) 856-5668

20 Mesh Screen	05-00-482
30 Mesh Screen	05-00-463
40 Mesh Screen	05-00-464
50 Mesh Screen	05-00-475
60 Mesh Screen	05-00-479
80 Mesh Screen	05-00-478
100 Mesh Screen	05-00-462
120 Mesh Screen	05-00-469
150 Mesh Screen	05-00-470
180 Mesh Screen	05-00-471
200 Mesh Screen	05-00-472
250 Mesh Screen	05-00-465
325 Mesh Screen	05-00-466
400 Mesh Screen	05-00-467

LOW VOLTAGE WIRING

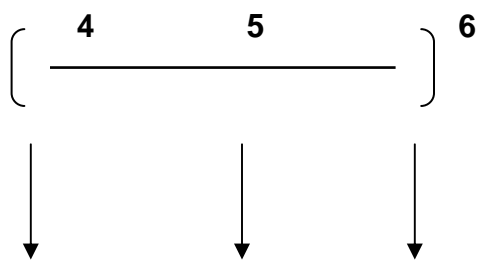

Motor leads 4-5-6 together tape

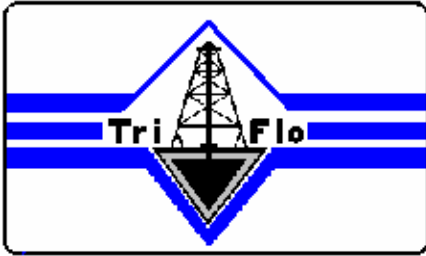

Tri-Flo Int'l, Inc.

P.O. Box 2626, Conroe, Texas 77305
 Bus: (936) 856-8551 Fax: (936) 856-5668

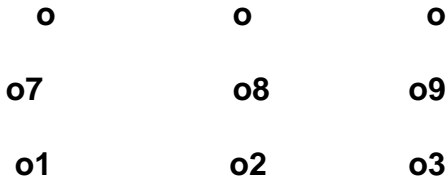

Motor leads 7-1 power lead 1 - tape
 Motor leads 8-2 power lead 2 - tape
 Motor leads 9-3 power lead 3 - tape

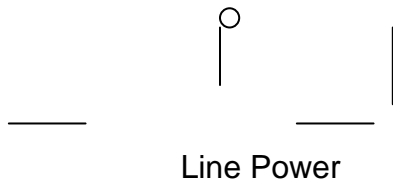

Note: The low voltage heater is a H29. TRI-FLO Part No. 01-00-042. If it is necessary to change from high voltage (460 V.A.C.) to low voltage (230 V.A.C.), the heater must be changed to H-29.

HIGH VOLTAGE WIRING

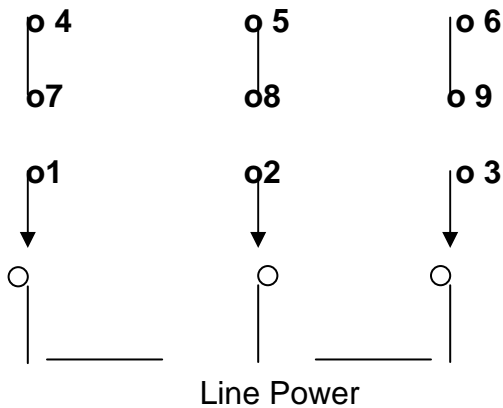

Motor lead 4-7 tape
 Motor lead 5-8 tape
 Motor lead 6-9 tape
 Motor lead 1 - to power lead 1 - tape
 Motor lead 2 - to power lead 2 - tape
 Motor lead 3 - to power lead 3 - tape

Note: High Voltage heater is a H23. TRI-FLO Part No. 01-00-055. If it is necessary to change from Low voltage (230 V.A.C.) to High voltage (460 V.A.C.), the heater must be changed to H-23.

NOTE: (If motor rotates in wrong direction reverse any two of the power leads.)
 NOTE: IF THE MOTOR JUNCTION BOX IS REWIRED OR CHANGED IT MUST BE JACKED WITH FOAM RUBBER TO PREVENT THE WIRES FROM RUBBING TOGETHER WHEN THE SHAKER IS VIBRATING.

TABLE

COMMON OILFIELD SHAKER SCREENS

MESH	WIRE DIAMETER	OPENING INCHES	OPENING MICRONS	% OPEN AREA
------	---------------	----------------	-----------------	-------------

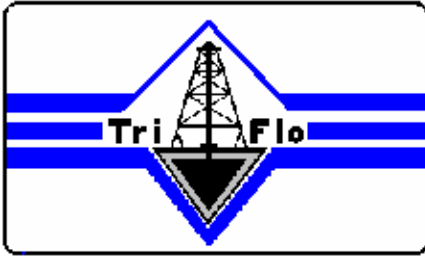

Tri-Flo Int'l, Inc.

P.O. Box 2626, Conroe, Texas 77305
 Bus: (936) 856-8551 Fax: (936) 856-5668

8 X 8	.028	.097	2464	60.2
10 X 10	.025	.075	1905	56.3
12 X 12	.023	.060	1524	51.8
14 X 14	.020	.051	1295	51.0
16 X 16	.018	.0445	1130	50.7
18 X 18	.018	.0376	995	45.8
20 X 20	.017	.033	838	43.6
8 x 20	.032/.020	.093/.030	2362/762	45.7
20 x 30	.015	.035/.0183	889/465	39.5
30 x 30	.012	.0213	541	40.8
30 x 40	.010	.0233/.015	592/381	42.5
40 x 36	.010	.015/.0178	381/452	40.5
40 x 40	.010	.015	381	36.0
50 x 40	.0085	.0115/.0165	292/419	38.3
50 x 50	.009	.011	279	30.3
60 x 40	.009	.0077/.016	200/406	31.1
60 X 60	.0075	.0092	234	30.5
70 X 30	.0075	.007/.026	178/660	40.3
80 X 80	.0055	.007	178	31.4
100 X 100	.0045	.0055	140	30.3
120 X 120	.0037	.0046	117	30.9
150 X 150	.0026	.0041	104	37.4
160 X 160	.0025	.0038	97	37.64
200 X 200	.0021	.0029	74	33.60

TENSION PLATE AND SCREEN ASSEMBLY

PART	TRI-FLO PART NO.
Tension Bolt Assembly (includes bolt, nut, spring, & 2 washers)	03-00-006
Tension Bolt (Item 20)	04-00-107

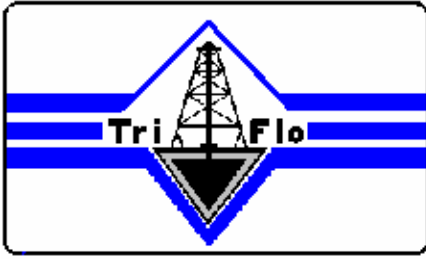

Tri-Flo Int'l, Inc.

P.O. Box 2626, Conroe, Texas 77305
 Bus: (936) 856-8551 Fax: (936) 856-5668

Tension Spring (Item 17)
 Tension Lock Nut (Item 21)
 Tension Washer (Item 22)
 Tension Rail Plate
 Screen

05-00-350
 04-00-150
 04-00-177
 03-00-007

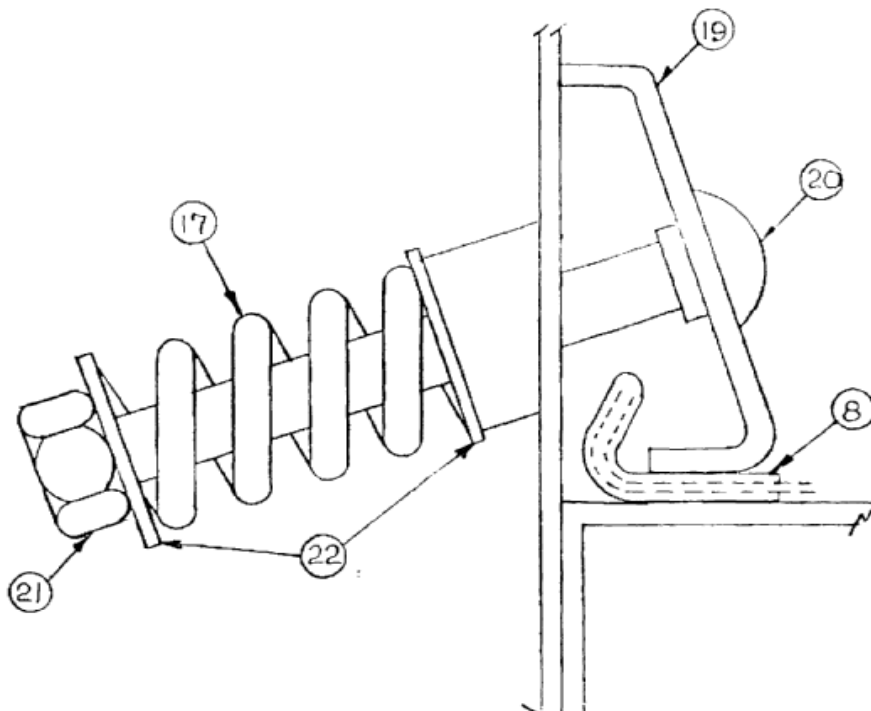

**TFI-113 VIBRATOR ASSEMBLY
 PARTS LIST**

A	1	03- 02-011	Vibrator Housing 03- 02-011
B	1	03-00-050	Vibrator Shaft

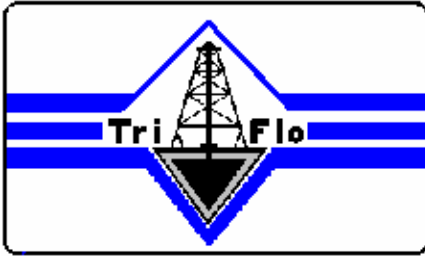

Tri-Flo Int'l, Inc.

P.O. Box 2626, Conroe, Texas 77305
 Bus: (936) 856-8551 Fax: (936) 856-5668

C	1	03-00-027	Retainer	
D	4	03-00-008	Spiro lox Ring - Retainer	*4
E	4	03-00-009	Sprio lox Ring - Cartridge	*4
G	1	05-00-349	Collar (Drive End)	
H	1	05-00-377	Collar (Opp End Drive)	
J	2	05-00-043	Bearing	*2
K	1	05-00-322	Retaining Ring - Shaft	*1
L	2	05-00-046	Set Screw	
M	2	05-00-186	Grease Fitting (Zert)	
P	2	04-00-090	Cap screw - 3/8"	
Q	8	04-00-169	Lock washer - 3/8"	
R	2	05-00-129	Counterweight	
S	2	04-00-109	Counterweight Bolt 5/8" x 4"	
T	2	05-00-345	Cartridge	*4
U	8	04-00-030	Cap screw 1/2"	
V	8	04-00-162	Lock washer - 1/2" Cartucho	
W	1	05-00-341	V-Belt Pulley	
X	1	05-00-082	V-Belt Pulley Bushing	
Y	1	05-00-239	Keystock 1/2" x 5/16" x 1 5/16"	
Z	1	05-00-240	Key stock 1/2" x 1/2" x 1"	

*** INDICATES QUANTITY OF RECOMMENDED SPARES**

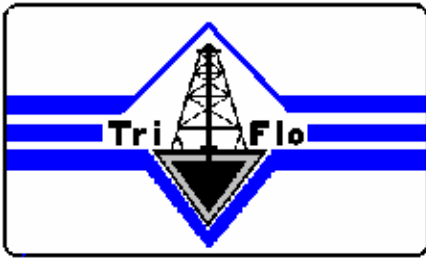

Tri-Flo Int'l, Inc.

P.O. Box 2626, Conroe, Texas 77305
 Bus: (936) 856-8551 Fax: (936) 856-5668

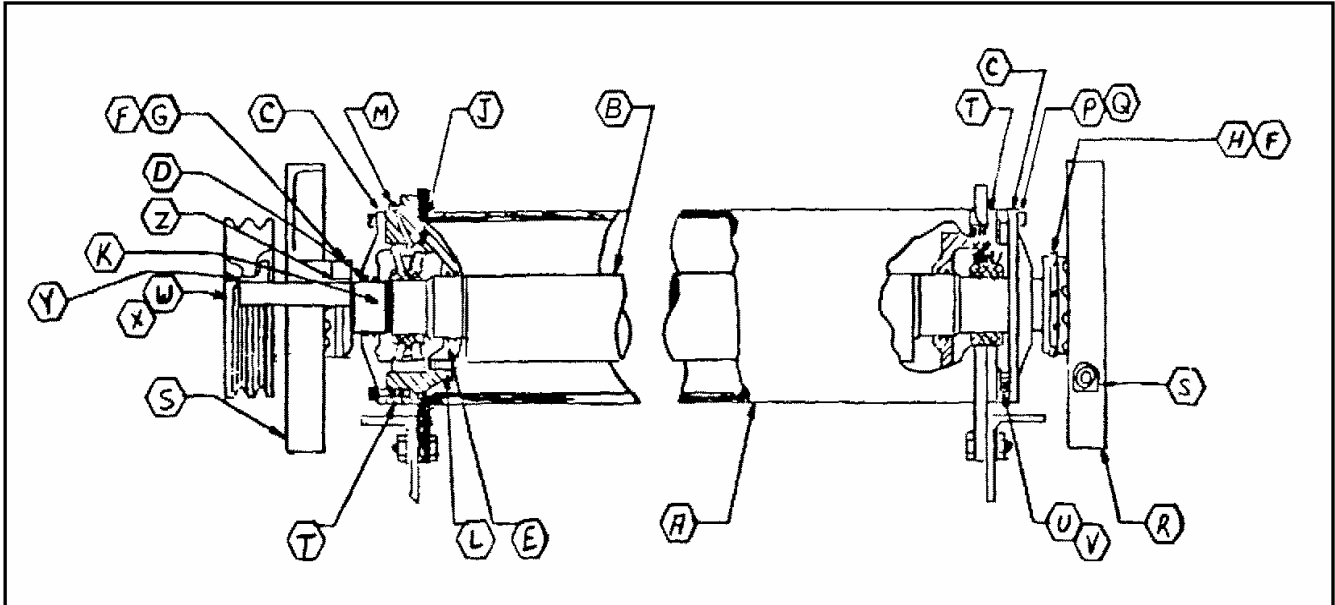

**TRI-FLO PARTS LIST
 TFI 113 SHALE SHAKER**

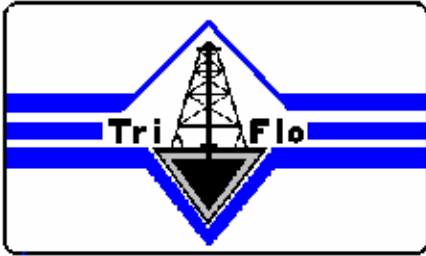

Tri-Flo Int'l, Inc.

P.O. Box 2626, Conroe, Texas 77305
 Bus: (936) 856-8551 Fax: (936) 856-5668

Part No.	Description
01-00-055	Heater Strip H-23
01-00-081	Starter - Size 0, Nema 12
01-00-099	Starter - Size 0, Nema
01-00-082	Starter Block
01-00-149	Motor- 2HP TENV 1800 RPM
01-00-145	Motor - 2HP XP 1800 RPM
03-00-004	Decking Rubber
03-00-005	Deck Spring
03-00-006	Tension Bolt Assembly
04-00-014	Tie Down Assembly
03-00-007	Tension Rail
03-00-008	Retainer Ring - Spiro lox
03-00-009	Cartridge Ring - Spiro lox
03-00-027	Bearing Retainer
03-00-050	Vibrating Shaft
04-00-090	Retainer Cap Screw
04-00-107	Tension Bolt
04-00-130	Cartridge Cap Screw
04-00-150	Tension Bolt Nut
04-00-162	Cartridge Lock Washer
04-00-169	Retainer Lock Washer
05-00-043	Bearing
05-00-046	Set Screw - Bearing Cartridge
05-00-063	05-00-069 (50hz) Drive Belt B-63 / B-64
05-00-084	Bushing (Vibrator)
05-00-082	Bushing (Motor)
05-00-129	Counterweight
05-00-239	Key stock Pulley
05-00-240	Key stock Collar
05-00-322	Shaft Retaining Ring
05-00-341	05-00-352 (50hz) Sheave 1B 5.6 SDS / 1B 6.8 SDS
05-00-345	Bearing Cartridge
05-00-349	Index Collar - Drive End
05-00-350	Tension Springs
04-00-177	Tension Bolt Washers
05-00-377	Index Collar - Non Drive End

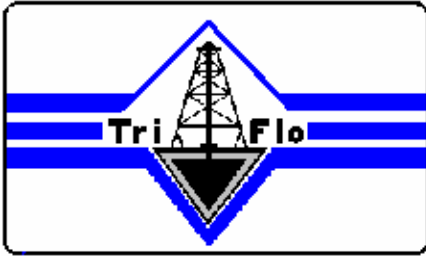

05-00-388

03-01-019

05-02-005

Tri-Flo Int'l, Inc.

P.O. Box 2626, Conroe, Texas 77305
Bus: (936) 856-8551 Fax: (936) 856-5668

Set Screw - Index Collar

Belt Guard - Complete

Counterweight Guard