

Tri-Flo Int'l, Inc.
P.O. Box 2626, Conroe, Texas 77305
Bus: (936) 856-8551 Fax: (936) 856-5668

SERVICE & OPERATING MANUAL

16 - 4" Mud Cleaner

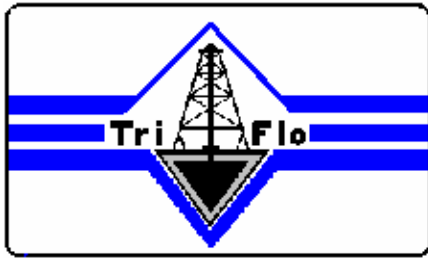



Tri-Flo Int'l, Inc.
P.O. Box 2626, Conroe, Texas 77305
Bus: (936) 856-8551 Fax: (936) 856-5668

TABLE OF CONTENTS

	Page
Introduction	3
Operation	4
Adjustments	5
Location	5
Maintenance	6
Troubleshooting	6
Installation	7
Power Requirements	8
Screen Installation	9
Lubrication	10
Adjustments	10
Rotation	10
Maintenance	11
Inspection	11
Disassembly of the Vibrator	12
Reassembly of the Vibrator	13
Changing Deck Springs	14
Troubleshooting	15
Electric Motors	15
Vibrator Assembly	15
Short Screen Life	16
Spare Parts	17
Safety	17
Tightening Torques for High strength Bolts	18
Forces	18
Recommended Lubricants	18
Screen Sizes	19
Vibrator Assembly Breakdown	20
Vibrator Assembly Drawing	21
Parts List	22
General Hook-Up for Mud Cleaner	23
Spray Discharge for Hydro cyclone	24
Location Diagram	25
Mechanical Solids Control for Weighted Drilling Fluid	26
Wiring Diagram	27
Tension Plate and Screen Assembly	28
Table of Common Oilfield Shaker Screens	29
Dimensions	30
Notes	31
INTRODUCTION	

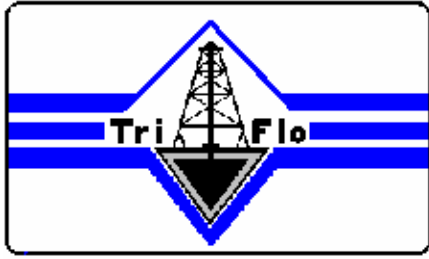

Tri-Flo Int'l, Inc.

**P.O. Box 2626, Conroe, Texas 77305
Bus: (936) 856-8551 Fax: (936) 856-5668**

The TRI-FLO 16 Cone Fluid Separator (Mud Cleaner) is a combination of a TRI-FLO Sand/Silt Separator and a TRI-FLO 146 Shale Shaker.

The TRI-FLO Fluid Separator is designed to remove the sand and silt sized particles before they have a chance to break down even smaller. The TRI-FLO Fluid Separator operates efficiently on weighted mud as well as unweighted mud systems.

The TRI-FLO Fluid Separator is designed to save barite and remove low gravity solids larger than barite from weighted mud system. The Sand/Silt Separator Hydro-cyclones will separate the low solid liquid slurry from the barite and larger than medium silt range particles. The barite and larger silt size particles will be directed on the screen surface to save barite and drilling fluid while the large silt size particles will go off the end of the screen.

On the unweighted mud systems the TRI-FLO Fluid Separator will reduce the costs by reduced jetting, less chemical replacement and less replacement of water and/or oil. With the use of 400 mesh screens it is possible to remove solids to approximately 25-micron silt size particle.

The TRI-FLO Fluid Separator has several design characteristics that justify its ability to remove sand and silt sized solids from the drilling fluid. The feed manifold is designed with an angled pitch to insure balanced feed pressure into the hydro cyclones. System balance is achieved by opening or closing individual control valves on each hydro cyclone, by lowering or raising the siphon tubes on each overflow tube, and/or increasing or decreasing the apex valve size. Any of these adjustments can alter the GPM rate and handle most volume requirements. These adjustments can make particle interference, mud viscosity, and rejection volume less critical and enable the system to work more efficiently. The TRI-FLO Fluid Separator can remove solids that are often found to be the cause of drill collar sticking and wear on mud pump expendables.

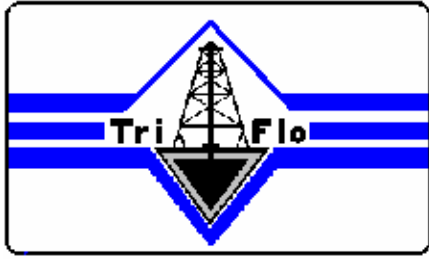

Tri-Flo Int'l, Inc.

P.O. Box 2626, Conroe, Texas 77305
Bus: (936) 856-8551 Fax: (936) 856-5668

OPERATION

The feed slurry of solids and liquid is fed through the inlet at a high velocity obtained by steady pressure of twenty-five **(25) psi**. The high velocity transmitted to the feed section creates a spinning velocity and resulting centrifugal forces. The vortex finder causes the stream to spiral downward towards the underflow solids discharge. Centrifugal force and inertia causes solids to settle outward toward the hydro cyclone wall, in a downward spiraling stream.

The solids separate according to size and weight of the particles. In the density range of solid particles in drilling fluids, size is of far more influence than the variations in density so that basically the biggest particles settle first and fastest.

The cone section narrows, inner layers of the downward spinning liquid turn back toward the overflow because of the increasing centrifugal forces near the center.

In the TRI-FLO's hydro cyclone, as the last of the liquid moves to the center and back upward toward the overflow, the downward spiraling solids continue out the apex, not being able to turn back because of their greater inertia and high downward velocity. Therefore, the actual solids removal at the underflow is by inertia, not by settling. The underflow rate and density varies with the volume and size of solids being separated to the underflow.

The TRI-FLO 16-4" Fluid separator can handle up to 1040 GPM of drilling fluid.

The TRI-FLO 8-4" Fluid Separator can handle up to 520 GPM of drilling fluid.

The TRI-FLO 6-4" Fluid Separator can handle up to 390 GPM of drilling fluid.

The TRI-FLO 4-4" Fluid Separator can handle up to 260 GPM of drilling fluid.

The TRI-FLO 2-4" Fluid Separator can handle up to 130 GPM of drilling fluid.

The underflow from the fluids, even under extreme conditions, will be approximately 40 GPM and ordinarily under 30 GPM. This makes it possible to use fine mesh screen (150-200 mesh) to clean all of the mud returning from the bore hole. 200 mesh screens have openings of 74 microns and the 150 mesh screens have openings of 104 microns. Theoretically, particles smaller than these openings should remain with the mud and larger particles and would be carried off the end of the shaker.

ADJUSTMENTS

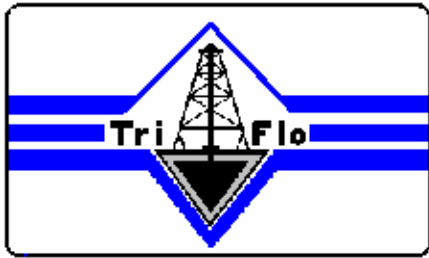

Tri-Flo Int'l, Inc.

P.O. Box 2626, Conroe, Texas 77305
Bus: (936) 856-8551 Fax: (936) 856-5668

The TRI-FLO Fluid Separator is operated at **25 psi** of pressure. A six (6) inch butterfly valve should be placed in the discharge line between the centrifugal pump and the manifold inlet. This valve would be used for adjusting the manifold pressure to 25 psi.

Each hydro cyclone has a two (2) inch butterfly valve located before the feed inlet. This valve permits the operator to turn off each hydro cyclone individually for system balance and removal of the hydro cyclone, without shutting down the entire system. TRI-FLO does not recommend this valve to be used as a flow adjustment and should be either fully open or fully closed.

The siphon tubes, located on the top of the overflow tubes are an adjustment of the underflow. When the siphon tube is completely down, the air entering the apex bushing is increased and less drilling fluid is permitted to spray out the apex of the hydro cyclone.

When a more wet underflow with more fine solids is desired, the siphon tube should be raised. This adjustment will reduce the amount of air permitted through the apex and cause a wetter underflow to travel to the shaker screen. The distance the siphon tube should be raised will vary with the drilling conditions and no hard fast rule will apply.

The apex nut and apex bushing are designed for easy removal when plugging becomes a problem and are adjustable to permit the required amount of spray discharge desired. When a smaller opening is necessary tighten the apex nut to the desired setting. The tighter the adjustment the less air permitted to enter the bottom of the hydro cyclone. At times when plugging is a problem, the apex nut and the apex bushing can be removed. This may be necessary when drilling a surface hole or when large amounts of sand are present.

CAUTION:

Over tightening of the apex nut and apex bushing will cause the hydro cyclone to become plugged. When the hydro cyclone becomes plugged severe erosion will occur in the feed section of the hydro cyclone and may damage the interior of the hydro cyclone. The damage will first be noticed in the zone of maximum wear on Figure 1 and may make the hydro cyclone virtually useless.

The TRI-FLO hydro cyclone consists of a feed section, cone section, apex nut, apex bushing and a clamp.

LOCATION

The TRI-FLO Fluid Separator should be mounted level on the mud tank next to the Shale Shaker. The centrifugal pump supplying the TRI-FLO Fluid Separator should have the suction in the compartment of the Shale Shaker discharge if a degasser is not used. If a degasser is used, the TRI-FLO Fluid Separator suction line should be in the compartment of the degasser's discharge. The TRI-FLO Separator should have a six (6) inch supply line from a separate centrifugal pump to the manifold inlet. See page 23.

MAINTENANCE

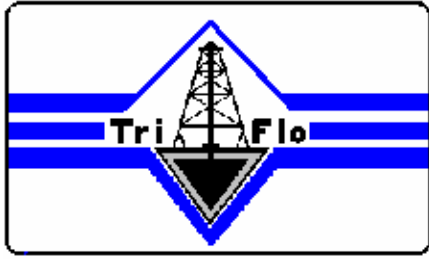

Tri-Flo Int'l, Inc.

**P.O. Box 2626, Conroe, Texas 77305
Bus: (936) 856-8551 Fax: (936) 856-5668**

The TRI-FLO Fluid Separator is a high performance piece of mud equipment and requires a regular maintenance program.

Hydro cyclone wear and performance is highly dependent of the feed pressure and the conditions of the hydro cyclones. The pressure should never exceed 25 psi, as more than 25 psi will cause excessive wear on the hydro cyclones.

Damaged or worn, hydro cyclones will not separate the fine drill solids from the drilling fluid and need to be checked periodically for wear.

TROUBLESHOOTING

PROBLEM: Pressure at the manifold too low:

CAUSE: Is the pump impeller large enough to deliver 25 psi?
Is the pump speed correct?
Is the supply line from the pump to the manifold six (6) in diameter?
Is the pump supplying any other piece of equipment?
Is the supply line to the manifold plugged?
Is the centrifugal pump suction plugged?

PROBLEM: No underflow or too little underflow:

CAUSE: Is the feed pressure at 25 psi?
Is the apex bushing plugged?
Is the apex bushing closed too tightly?
Are there fine-drilled solids in the mud?
Is the valve to the hydro cyclone open?
Is the pump running?

PROBLEM: Too much underflow:

CAUSE: Is the hydro cyclone feed suction or cone section damaged?
Is the apex bushing in the hydro cyclone?
Is the pressure too high?

INSTALLATION

LOCATION

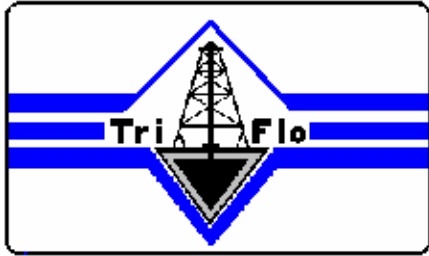

Tri-Flo Int'l, Inc.

P.O. Box 2626, Conroe, Texas 77305
Bus: (936) 856-8551 Fax: (936) 856-5668

The TRI-FLO 146 High Speed SHALE SHAKER should be mounted at the end of the mud tank at least 8' wide by 9' long. The TRI-FLO 146 High Speed SHALE SHAKER should be mounted with the inlet towards the flow line and the skid secured to the mud tank.

It is important that the TRI-FLO 146 High Speed SHALE SHAKER be mounted level. This will aid in an efficient operation.

After mounting remove the four shipping bolts. These bolts are located at each spring coil on the vibrating deck.

MUD TROUGH

Place the mud trough in place at the mud inlet on the skid base and place a blanking plate in the unused outlet.

FLOWLINE

Connect a flow line between the bell nipple and the mud inlet of the TRI-FLO 146 High Speed SHALE SHAKER.

It is not recommended to run the flow line into the top of the possum belly, as it will reduce the volume of the mud the screens can handle.

SHALE SLIDE

If it is not desirable to permit the cuttings or solids to drop off the end of the screen, it will be necessary to construct a shale slide from the end of the TRI-FLO High Speed SHALE SHAKER to the shale pit. This slide should be as steep as possible. Water spray may be added to wash the cuttings into the shale pit.

POWER REQUIREMENTS

Connect the power cable from the motor starter switch to the rig power supply. Connect the green insulated wire to ground.

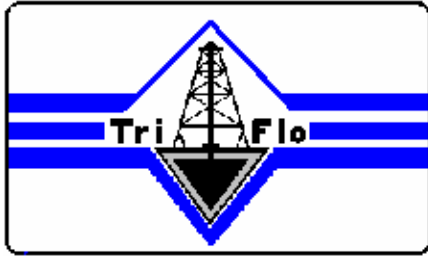

Tri-Flo Int'l, Inc.

**P.O. Box 2626, Conroe, Texas 77305
Bus: (936) 856-8551 Fax: (936) 856-5668**

The TRI-FLO High Speed SHALE SHAKER is normally wired at the factory for 460 V.A.C., 60 HZ, and 3 PHASE.

If 230 V.A.C., 60 HZ, 3 PHASE is needed it is necessary to:

1. Rewire the motor. (See motor wiring diagram on Page 27)
2. Change the heater strips on the motor starter switch.
3. The motor junction box must be packed with foam rubber to prevent the wires from rubbing together when the shaker is vibrating. This is necessary after the rewiring is completed.

Turn the starter switch on and check the motor rotation. The top of the belt should travel in the same direction as the flow of the mud. This is from the front of the shaker to the back.

If the rotation is incorrect, change any two of the red, black or white wires at the motor junction box at the rig power supply. The green wire should always be ground and would not effect the rotation of the motor.

SCREENS

The procedure to install or change the screens is as follows:

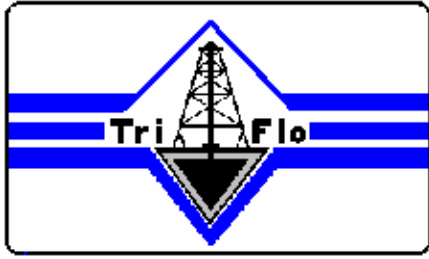

Tri-Flo Int'l, Inc.

**P.O. Box 2626, Conroe, Texas 77305
Bus: (936) 856-8551 Fax: (936) 856-5668**

1. Remove the tension lock nuts, washers, tension springs, the tension bolts and the tension rail plates from the screen box. (See tension plate detail on Page 28) on the screen support bars.
2. Install decking rubber on the screen support bars.
3. Install the screen in position, leaving equal space on each side. When installing the screen be careful not to bend or crease these screens.
4. Put the tension plates in position with the bolts extending through their respective holes in the side plates of the screen box. The tension rail plates should only touch the hook strips and not the screen.
5. Install the springs, washers and lock nuts. Tighten the tension lock nuts to expose 1/8" of the threads, starting at the center tension lock nuts and working toward each end.
6. Check the screen for creases and ripples. If any appear, the hook strips are not even. Work out the wrinkles by hand by adjusting the position of the hook strips and by smoothing the screen cloth by hand.
7. Tighten the center tension lock nuts to expose 5/8" of threads, then tighten the other nuts the same amount, working from one side and the other.
8. Tighten the nuts just enough to fully compress the tension springs. Rap the tension plate and the tension bolt heads lightly with a hammer to insure that the bottom of the tension plate is parallel to the support bar. After fully compressing the springs they will maintain tension on the screens. It is recommended that after 3 hours the tension nuts should be retightened.
9. Wet the screen with water (or diesel when using oil mud) before diverting mudflow over the screen.

LUBRICATION

TRI-FLO recommends that the grease fillings located on top of each cartridge be greased every twelve hours. Normal service requires approximately 1/2 ounce of grease in each bearing every 12 hours.

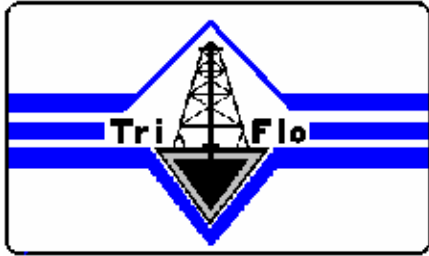

Tri-Flo Int'l, Inc.

P.O. Box 2626, Conroe, Texas 77305
Bus: (936) 856-8551 Fax: (936) 856-5668

ADJUSTMENTS

The intensity of vibrations may be varied to suit conditions by changing the position of the adjustable counterweights. Position 1 gives the maximum, and each successive notch or setting reduces the motion. Position 6 gives the minimum intensity of vibrations. IT IS IMPORTANT THAT BOTH COUNTERWEIGHTS HAVE THE SAME SETTING. This is easily checked by the alignment on the notches in the counterweights.

VIBRATOR ROTATION

The direction of rotation is normally with the flow of the material. In some situations, for a different retention time, the rotation can be opposite the flow of the material (counter flow). Reversing the electrical leads to the motor does changing from one to the other.

Other factors such as screen incline and vibrator speed may be adjusted under some circumstances, under the guidance and direction of TRI-FLO INDUSTRIES INTERNATIONAL, INC.

MAINTENANCE

INSPECTION

A regular schedule of complete dismantling, inspection, and relubrication intervals assures maximum screen life and minimum downtime. The customer should keep a complete record of all

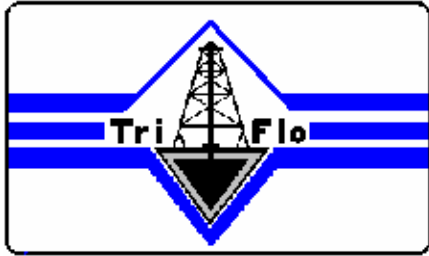

Tri-Flo Int'l, Inc.

P.O. Box 2626, Conroe, Texas 77305
Bus: (936) 856-8551 Fax: (936) 856-5668

such preventive maintenance plus a record of any repairs. Since the TRI-FLO High Speed SHALE SHAKER is a vibratory machine, it is important to correct all minor troubles before serious damage develops. Replace faulty support springs and any missing bolts at once. Cracks forming in the structure (usually at or near the joints) and unusual noises and motion are signs of developing failure. Drill 1/4" holes thru the ends of such cracks and consult TRI-FLO at once in the event of such failures. **WARNING IF WELDING IS DONE TO NO GROUND WELDER THRU VIBRATING SCREEN.**

After 1500 to 2000 hours of operation, dismantle the vibrator mechanism and clean all parts. Flush bearings with a 200° light transformer, or automotive flushing oil. Check screen tension periodically. On reassembly, pack the bearings with grease and fill the adjacent cavity in the housing and retainer with grease to the bottom of the shaft.

DISASSEMBLY OF THE VIBRATOR

WARNING: DISCONNECT POWER TO THE ELECTRIC MOTOR AND LOCK THE DISCONNECT SWITCH IN THE OPEN POSITION.

1. Remove motor and drive pulley guard.

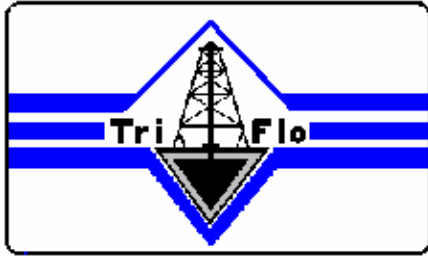

Tri-Flo Int'l, Inc.

P.O. Box 2626, Conroe, Texas 77305
Bus: (936) 856-8551 Fax: (936) 856-5668

2. Remove the counterweight guard from both ends of the vibrator shaft.
3. Loosen the four motor support bolts located under the motor, loosen the V-belts and remove them.
4. Remove the V-belt sheave (Item W, Page 20), by first loosening its taper lock hub.
5. Remove the counterweights (Item R, Page 20), by removing the clamp screws and reusing the screw to open the slots in the counterweights, by tightening the screws into the tapped holes.
6. Remove the collars (Item G, Page 20) and the retainers (Item C) with the Spiro lox rings (Item D) in their grooves. Remove cartridge cap screws (Item U).
7. Remove retaining ring (Item K) from the drive side only. By striking on one end of the shaft (Item B) with a lead hammer or a hammer and a block of hardwood, it is possible to start to drive out the cartridge (Item T) on the other side.
8. Then it should be easy to pry either or both cartridges loose from their bores in the housing ends. If difficulty is experienced a cartridge can be bumped from the inside by striking the shaft again at the other end. When one cartridge is removed the shaft can be slipped from the housing.
9. The bearing remaining in the other cartridge should be removed by using 3 long 3/8" NC cap screws and pushing the bearing out. Before inserting the cap screws, the setscrews must be removed.

ASSEMBLY OF THE VIBRATOR

1. Be sure the housing, cartridges, bearings, shafts, etc. are clean. Flush the bearing with (200° F) light transformer, spindle, or automotive flushing oil; DO NOT USE KEROSENE OR GASOLINE.

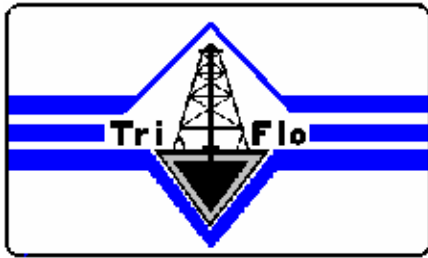

Tri-Flo Int'l, Inc.

**P.O. Box 2626, Conroe, Texas 77305
Bus: (936) 856-8551 Fax: (936) 856-5668**

2. Make a sub-assembly of the bearing, cartridges, Spiro lox rings (Item E, Page 20), and the setscrews (Item L). The latter must be replaced in the cartridges as in the original assembly if they have been removed to use longer cap screws for bearing removal.
3. Position and secure on such cartridge-bearing sub-assembly in the housing end on the drive side. Slide the shaft thru the housing from the other side and slip it through the bearing bore. Rotate the shaft while installing the Spiro lox rings (Item E). Secure the shaft axially to the drive side bearing by forcing the retaining ring (Item K) into its groove in the shaft.
4. Slip the other cartridge-bearing sub-assembly over the shaft on the side opposite the drive end. Push and tap it into position in the housing end, lifting on the shaft end to center all components properly. Secure cartridges with cap screws (Item U) and lock washers (Item V). See Page 18 for torques of the cap screws.
5. Be sure that the shaft and bearings turn freely. Pack both bearings with recommended grease. See Page 18 for recommended grease.
6. Slip Spiro lox rings (Item D, Page 20) into the retainer grooves. Pack the retainers (Item C) with grease to the bottom of the shaft. Slip over the shaft ends, push into position, and fasten with cap screws (Item R). Torque all bolts and cap screws on the vibrator assembly to specifications listed on Page 18 **TIGHTENING TORQUES FOR HIGH-STRENGTH BOLTING.**
7. Put indexing collars (Item G & Item H) on shafts. The notched edge of these collars should face the shaft ends. Looking down on these collars, the numbers on the indexing bands will read counter clockwise on one side and clockwise on the other side. Secure the setscrew collars over the key.
8. Mount the counterweight (Item R) on the shafts using the clamp screw in the tapped hole to open the slot to facilitate mounting. Make certain that the projecting lugs of each counterweight engage with the corresponding numbered notches in the indexing collars (Item G & Item H) to produce equal unbalancing or vibrating effects at each end of the shaft.
9. Remove the clamp screw from the tapped hole and insert into the through hole in the counterweight. Secure the counterweight by tightening the clamp screws.
10. Install the V-belt sheave (Item W) and it's Taper-Lock bushing onto the shaft by tightening the screw in the Taper-Lock bushing.
11. Install the matched set of V-belts and tighten the motor support bolts after the V-belts are adjusted. Tighten only enough to prevent slippage when starting and to prevent belt whip.

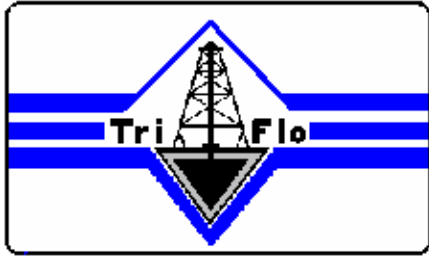

Tri-Flo Int'l, Inc.

**P.O. Box 2626, Conroe, Texas 77305
Bus: (936) 856-8551 Fax: (936) 856-5668**

12. Install the counterweight guards and the motor pulley guard.
13. Check the bolts for fastening the vibrator housing to the screen box. These bolts should be tightened to 210 ft. lbs. See Page 18 for bolt torque.

CHANGING THE SPRING COILS ON VIBRATING DECK

The Spring Coils on the vibrating deck should be checked every 6 months. When the spring shrinks or collapses to less than 4 inches they should be replaced. A new spring measures 4-1/2 inches. Lifting the shaker box, removing the old springs, and installing the new ones does this.

TROUBLESHOOTING

ELECTRIC MOTOR

1. Check for loose bearings.
2. Check the mounting bolts.

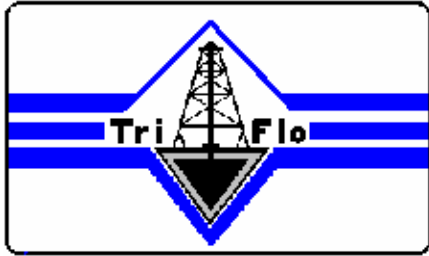

Tri-Flo Int'l, Inc.

P.O. Box 2626, Conroe, Texas 77305
Bus: (936) 856-8551 Fax: (936) 856-5668

3. Check the belt tension.
4. Inspect the power cable for wear between the switch and the motor.

VIBRATOR MECHANISM

Overheating of the Vibrator

1. CAUSE: Too little lubricant
SOLUTION: Check seals for leakage and add lubricant.
2. CAUSE: Too much lubricant
SOLUTION: Remove lubricant until proper amount is indicated.
3. CAUSE: High ambient temperature caused by handling hot material or by surrounding condition.
SOLUTION: Ventilate area or use high temperature lubricant.

Lubricant Leakage

1. CAUSE: High temperature causes grease to become fluid and leak thru the seals.
SOLUTION: Use high temperature grease.

Gritty Bearing

1. CAUSE: Entrance of grit while servicing or through the seals during operation.
SOLUTION: Flush bearing and cartridge and relubricate.

Noisy Bearing

1. CAUSE: Bearing failure caused by mentioned reasons.
SOLUTION: Replace bearings: take necessary precautionary steps to avoid reoccurring failure.
2. CAUSE: Normal fatigue failure associated with the vibrator service-identified by spalling or roller and inner race at the high load zone.
SOLUTION: Replace the bearings; see assembly instructions.

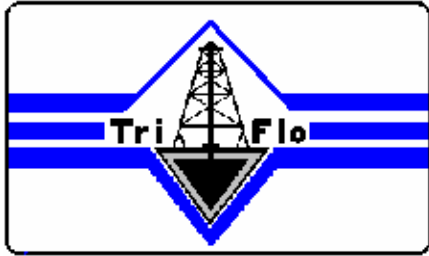

Tri-Flo Int'l, Inc.

P.O. Box 2626, Conroe, Texas 77305
Bus: (936) 856-8551 Fax: (936) 856-5668

Erratic Vibration or Performance

1. CAUSE: Slipping of the V-belts.
SOLUTION: Replace worn belts or tighten belts by adjusting the motor slide base.
2. CAUSE: Throwing of V-belts.
SOLUTION: Check belt alignment; check counter weights to insure they are on the same number.
3. CAUSE: Unit is not level
SOLUTION: Relevel the shaker with shims.

SHORT SCREEN LIFE

1. Careless handling and installation.
2. Failure to clean all support surfaces prior to screen installation.
3. Improper tension during installation.
4. Tension plates are not seated properly.
5. Cuttings build up under the edge of the screen.
6. Worn or dirty deck rubber.

SPARE PARTS

Always order spare parts from TRI-FLO INDUSTRIES INTERNATIONAL. This is particularly true of bearings, which may not be available from the local bearing sources because of special internal clearance requirements.

It is advisable to stock the following parts so that breakdowns can be repaired promptly and costly delays eliminated.

Name of Part	Quantity Each Screen	Part No.
---------------------	-----------------------------	-----------------

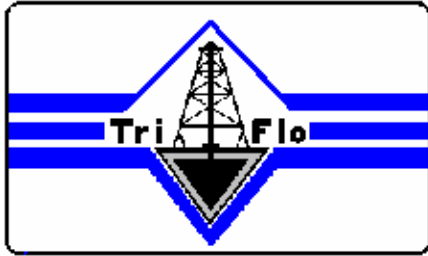

Tri-Flo Int'l, Inc.

P.O. Box 2626, Conroe, Texas 77305
 Bus: (936) 856-8551 Fax: (936) 856-5668

Bearing	2	05-00-044
Bearing Cartridge	1	05-00-346
V-belts, Matched Set	2	05-00-066
Tension Bolt Assembly (includes bolts, nut, spring and 2 washers)	6	03-00-006
Spiro lox ring-retainer	4	03-00-008
Prolix ring-cartridge	4	03-00-010
Spring, Coil (Vibrating Deck)	4	03-00-005
Retaining ring	1	05-00-321

SAFETY

NO PERSON SHOULD STAND, HOLD OR LEAN AGAINST THE VIBRATING FRAMES. VIBRATIONS TRANSMITTED TO THE HUMAN BODY CAN BE HARMFUL. THESE SCREENS ARE NOT THERAPEUTIC DEVICES.

BECAUSE OF THE MOTION OF THE VIBRATING SCREEN IT IS IMPOSSIBLE TO SERVICE THE SHAKER WHILE IN MOTION. NEVER LAY TOOLS OR SPARE PARTS ON THE SCREENS.

ONLY TRAINED PERSONNEL SHOULD OPERATE OR REPAIR THIS SHAKER.

TIGHTENING TORQUES FOR HIGH-STRENGTH BOLTS

Cap Screw or bolt Diameter, inches	Torque foot•pounds	
	Bolts	Cap screws
3/8"	41	47
1/2"	105	120
5/8"	210	210

FORCES

Forces generated by TRI-FLO's 146-T vibration screen at various counterweight settings.

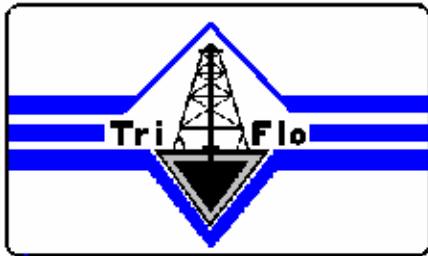

Tri-Flo Int'l, Inc.

P.O. Box 2626, Conroe, Texas 77305
 Bus: (936) 856-8551 Fax: (936) 856-5668

Settings	Unbalance (inch-lbs)	Stroke (inches)	Forces (g's)
1	86.0	.147	6.4
2	83.6	.142	6.2
3	75.9	.129	5.6
4	63.8	.109	4.7
5	48.6	.083	3.6
6	33.5	.057	2.5

RECOMMENDED LUBRICANTS

Shell Oil Co.	Alvania No. E P-2
Texaco Inc.	Multifax No. E P-2
Gulf Oil Co.	Crown No. 2
Chevron Oil Co.	Duralith No. E P-2
Mobil Oil Corp.	Mobilux E P-0,1,2
Universal	Mollux No. 3400
Citgo	Mystik SX-6 Extreme Temp. -65 to 350 degrees
Citgo	Mystik JT-6 High Temp.

TFI 146 SHAKER SCREENS		
Part No.	Description	
TRI-FLO 4' x 3' STANDARD SCREEN		
05-00-378	4 x 3 - 10 Mesh Screen	
03-00-013	4 x 3 - 20 Mesh Screen	
03-00-014	4 x 3 - 30 Mesh Screen	
03-00-015	4 x 3 - 40 Mesh Screen	
03-00-016	4 x 3 - 50 Mesh Screen	
03-00-017	4 x 3 - 60 Mesh Screen	
03-00-018	4 x 3 - 80 Mesh Screen w/ backup	
03-00-019	4 x 3 - 100 Mesh Screen w/ backup	

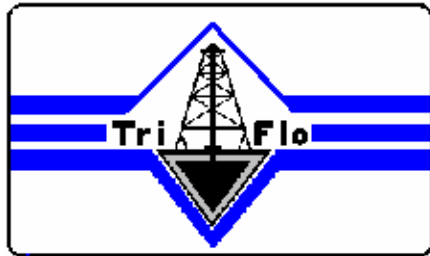

Tri-Flo Int'l, Inc.

P.O. Box 2626, Conroe, Texas 77305
 Bus: (936) 856-8551 Fax: (936) 856-5668

03-00-020	4 x 3 - 120 Mesh Screen w/ backup	
03-00-021	4 x 3 - 150 Mesh Screen w/ backup	
03-00-026	4 x 3 - 165 Mesh Screen w/ backup	
05-00-417	4 x 3 - 175 Mesh Screen w/ backup	
05-00-397	4 x 3 - 180 Mesh Screen w/ backup	
03-00-022	4 x 3 - 200 Mesh Screen w/ backup	
05-00-391	4 x 3 - 250 Mesh Screen w/ backup	
05-00-390	4 x 3 - 325 Mesh Screen w/ backup	
05-00-405	4 x 3 - 400 Mesh Screen w/ backup	
TRI-FLO 4' x 3' STANDARD SCREEN w/ 2" PLASTIC BACK		
05-00-418	4 x 3 - 38 Mesh Screen	
05-00-419	4 x 3 - 50 Mesh Screen	
05-00-420	4 x 3 - 70 Mesh Screen	
05-00-434	4 x 3 - 80 Mesh Screen	
05-00-421	4 x 3 - 84 Mesh Screen	
05-00-435	4 x 3 - 100 Mesh Screen	
05-00-423	4 x 3 - 110 Mesh Screen	
05-00-436	4 x 3 - 120 Mesh Screen	
05-00-424	4 x 3 - 140 Mesh Screen	
05-00-437	4 x 3 - 150 Mesh Screen	
05-00-438	4 x 3 - 165 Mesh Screen	
05-00-425	4 x 3 - 175 Mesh Screen	
05-00-439	4 x 3 - 180 Mesh Screen	
05-00-440	4 x 3 - 200 Mesh Screen	
05-00-426	4 x 3 - 210 Mesh Screen	
05-00-428	4 x 3 - 250 Mesh Screen	
05-00-442	4 x 3 - 300 Mesh Screen	
05-00-443	4 x 3 - 400 Mesh Screen	

TFI-146 SHALE SHAKER VIBRATOR BREAKDOWN

ITEM	QTY	PIN	DESCRIPTION
A	1	03-00-591	Vibrator Housing
B	1	03-00-039	Vibrator Shaft
C	1	05-00-379	Retainer
D	4	03-00-008	Spiro lox Ring – Retainer *4
E	4	03-00-010	Spiro lox Ring – Cartridge *4
F	2	05-00-388	Set Screw for Collar
G	1	05-00-349	Collar (Drive End)
H	1	05-00-377	Collar (Opp End Drive)
J	2	05-00-044	Bearing *2
K	1	05-00-321	Retaining Ring *1
L	6	05-00-046	Set Screw

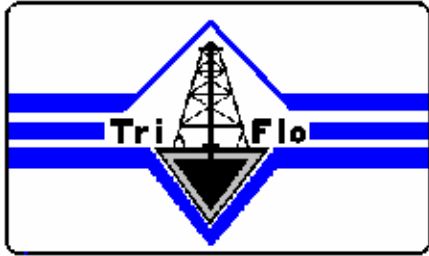

Tri-Flo Int'l, Inc.

P.O. Box 2626, Conroe, Texas 77305
 Bus: (936) 856-8551 Fax: (936) 856-5668

M	2	05-00-186	Grease Fitting (Zert)
P	8	04-00-090	Cap screw - 3/8"
Q	8	04-00-169	Lock washer - 3/8"
R	2	05-00-129	Counterweight
S	2	04-00-109	Counterweight Bolt 5/8" x 4"
T	2	05-00-346	Cartridge
U	8	04-00-130	Cap screw 1/2" Grade 8
V	8	04-00-162	Lock washer 1/2"
W	1	05-00-344	V Belt Pulley
X	1	05-00-083	V Belt Pulley Bushing
Y	1	05-00-239	Key stock 1/2" x 1/2" x 1 1/4"
Z	1	05-00-240	Key stock 1/2" x 1/2" x 1"

*** INDICATES QUANTITY OF RECOMMENDED SPARES**
***SEE PAGE 21 FOR DRAWING**

TFI 146 VIBRATOR ASSEMBLY

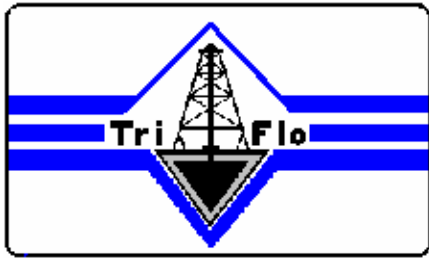

Tri-Flo Int'l, Inc.
 P.O. Box 2626, Conroe, Texas 77305
 Bus: (936) 856-8551 Fax: (936) 856-5668

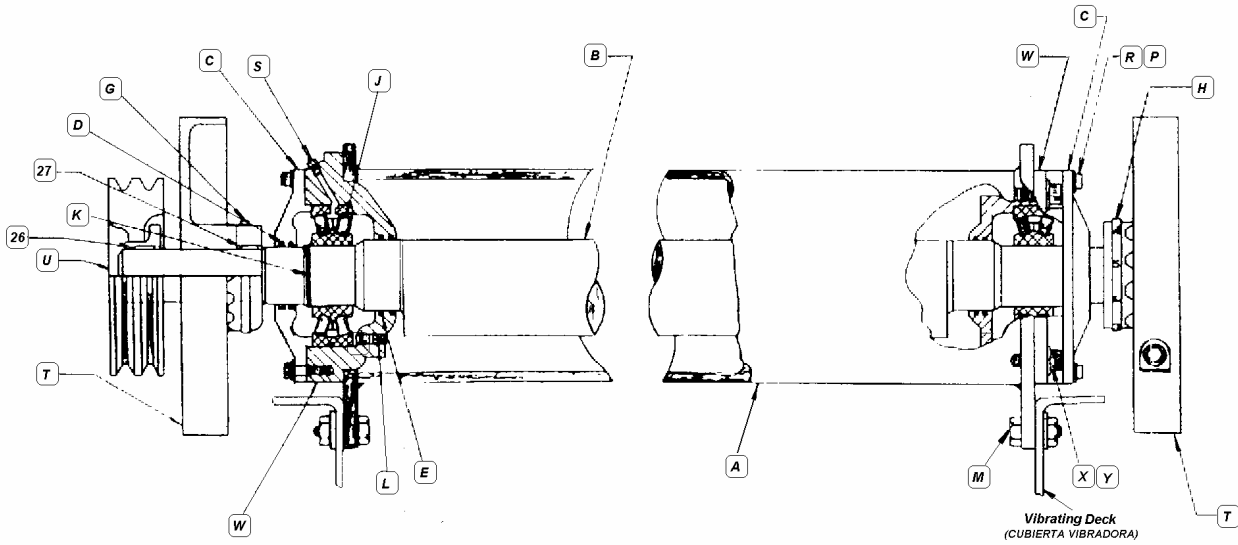

TFI 146 SHALE SHAKER		

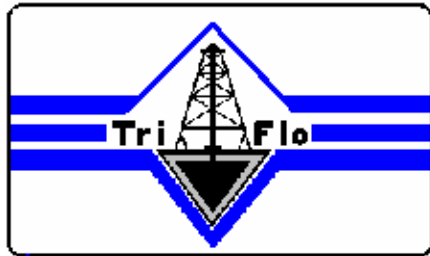

Tri-Flo Int'l, Inc.

P.O. Box 2626, Conroe, Texas 77305
 Bus: (936) 856-8551 Fax: (936) 856-5668

Part No.	Description	
01-00-041	Heater Strip H-26	
01-00-081	Starter - Size 0 Nema 12 Water Proof	
01-00-099	Starter - Size 0 Nema	
01-00-082	Starter Block	
01-00-123	Motor - 3HP TEFC 1800 RPM	
01-00-128	Motor - 3HP XP 1800 RPM	
03-00-004	Decking Rubber	
03-00-011	Deck Spring - Heavy Duty	
03-00-006	Tension Bolt Assembly	
04-00-014	Tie Down Bolt Assembly	
04-00-107	Tension Bolt	
04-00-150	Tension Nut	
05-00-350	Tension Spring	
04-00-177	Tension Washers	
03-00-007	Tension Rail	
03-00-008	Retainer Ring - Spiro lox	
03-00-010	Cartridge Ring - Spiro lox	
03-00-039	Vibrating Shaft	
04-00-162	Cartridge Lock Washer	
04-00-169	Retainer Lock Washer	
05-00-044	Bearing	
05-00-046	Set Screw - Bearing Cartridge	
05-00-344(00-00-401 50HZ)	Sheave	
05-00-083	Motor Bushing	
05-00-084	Shaft Bushing	
05-00-063(066 -50HZ)	Drive Belt (B-42) / (B-44 50HZ)	
05-00-131	Counterweight Balance	
04-00-103	Cartridge Cap Screw	
04-00-029	Retainer Cap Screw	
05-00-239	Key stock Pulley	
05-00-240	Key stock Collar	
05-00-321	Shaft Retaining Ring	
05-00-346	Bearing Cartridge	
05-00-349	Index Collar - Drive End	
05-00-377	Index Collar - Non Drive End	
05-00-379	Bearing Retainer	
05-00-388	Set Screw - Index Collar	
01-00-109	10/4 S.O. Cord	

Drawing - General Hook-up for Mud Cleaner/Sand Silt Separator

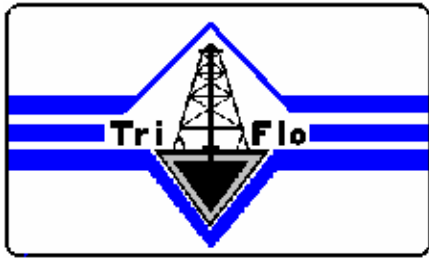

Tri-Flo Int'l, Inc.
 P.O. Box 2626, Conroe, Texas 77305
 Bus: (936) 856-8551 Fax: (936) 856-5668

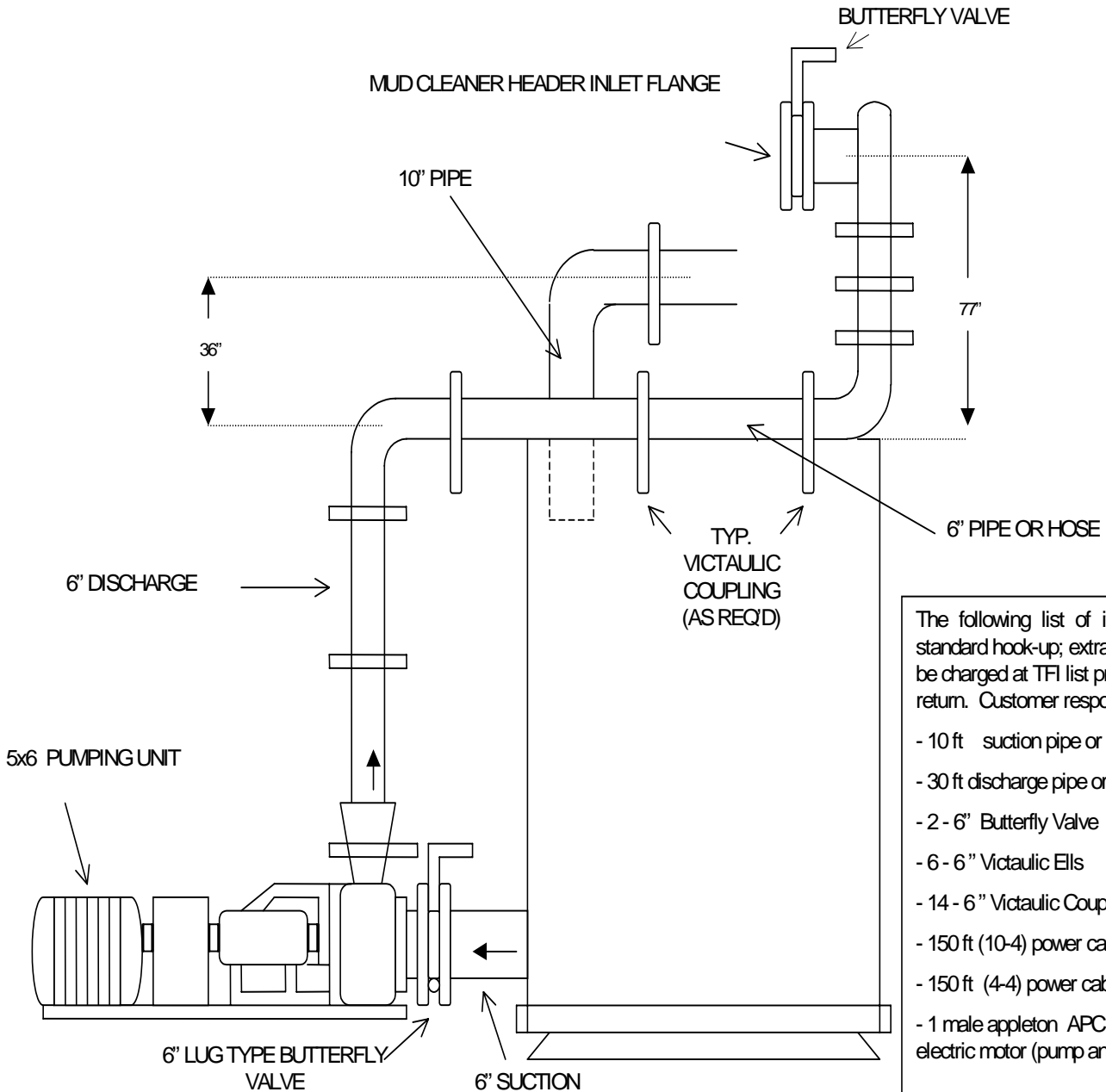

The following list of items are considered standard hook-up; extra material required will be charged at TFI list price and credited upon return. Customer responsible for welding:

- 10 ft suction pipe or hose
- 30 ft discharge pipe or hose
- 2 - 6" Butterfly Valve
- 6 - 6" Victaulic Ells
- 14 - 6" Victaulic Coupling
- 150 ft (10-4) power cable (shaker)
- 150 ft (4-4) power cable (pump)
- 1 male appleton APC 1034 plug per electric motor (pump and/ or shaker).

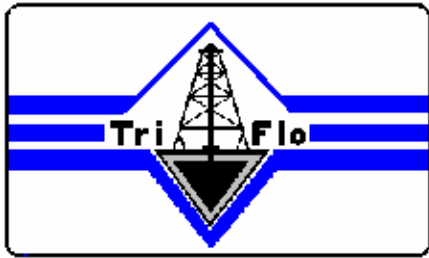

Tri-Flo Int'l, Inc.
 P.O. Box 2626, Conroe, Texas 77305
 Bus: (936) 856-8551 Fax: (936) 856-5668

Drawing: Spray Discharge of Hydro cyclone

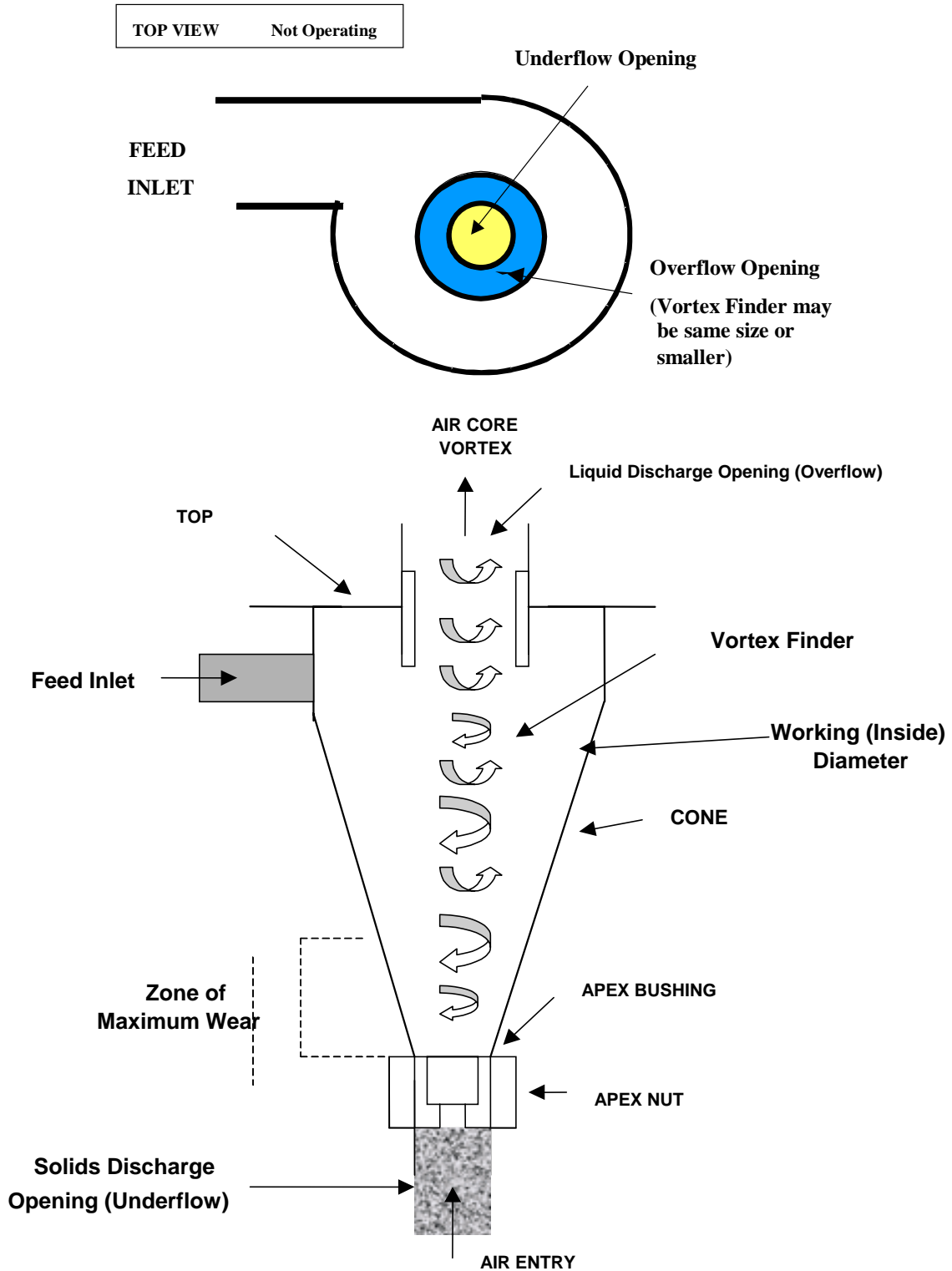

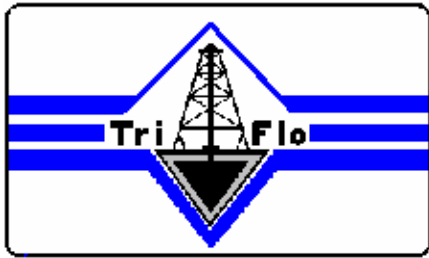

Tri-Flo Int'l, Inc.
 P.O. Box 2626, Conroe, Texas 77305
 Bus: (936) 856-8551 Fax: (936) 856-5668

Drawing: Location Diagram

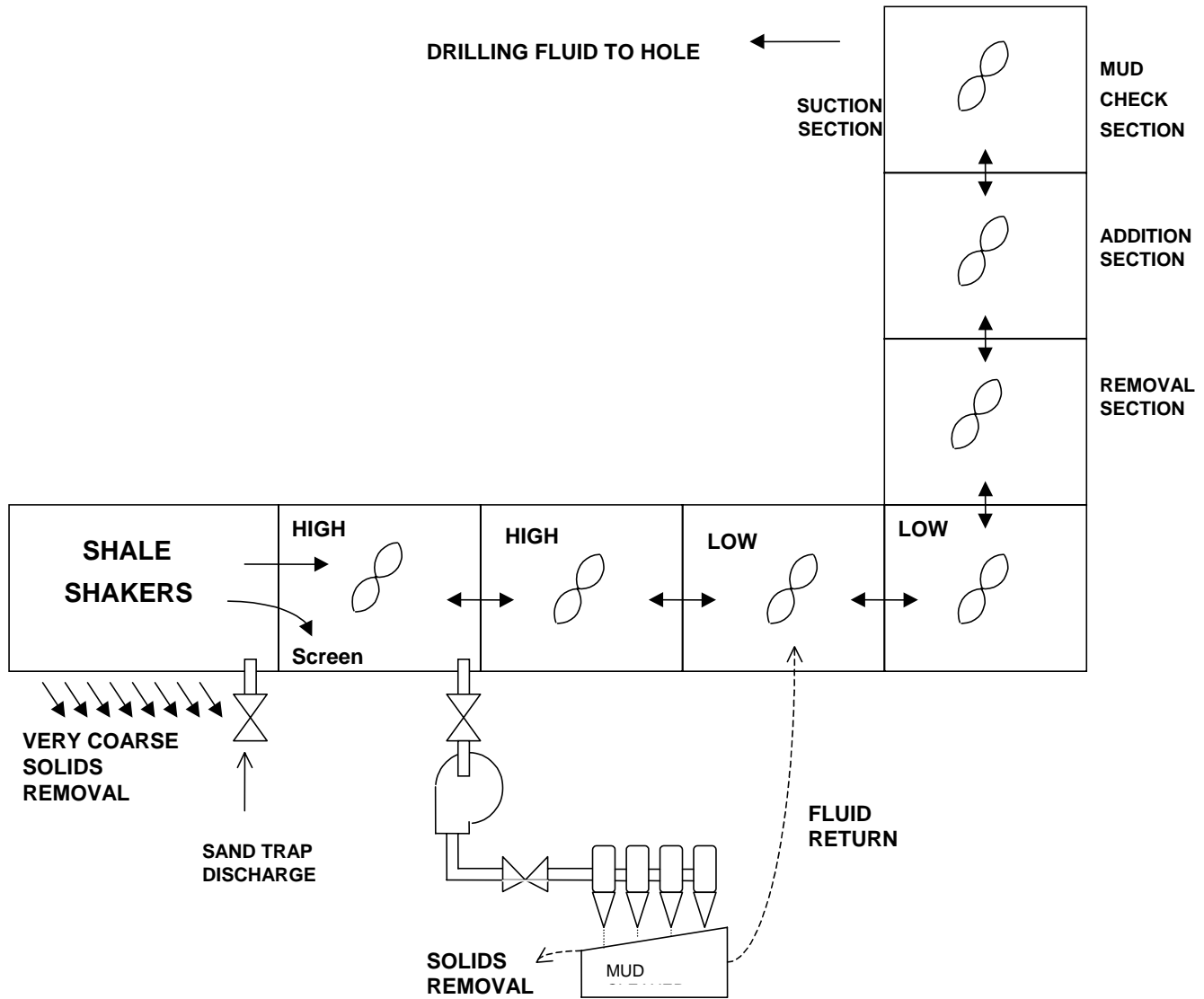

Drawing: Mechanical Solids Control of Weighted Drilling Mud

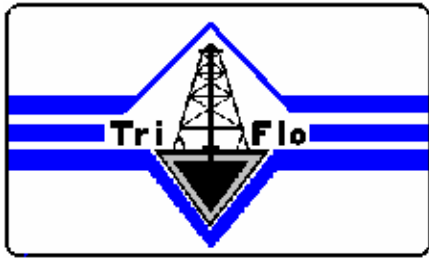

Tri-Flo Int'l, Inc.

P.O. Box 2626, Conroe, Texas 77305
 Bus: (936) 856-8551 Fax: (936) 856-5668

Centrifuge

Removes low gravity solids and Barite smaller than 15 microns.

Returns smaller solids to active mud system.

Operates on small fraction of total mud system.

Mud Cleaner

Removes drilled solids larger than 74-105 microns before they degrade onto ultra fine solids, which cause viscosity build-up. Small amounts of oversized Barite and some colloidal Barite may be removed with drilled solids.

Returns smaller solids including barite to active system.

Operates on entire circulating volume.

Fine Screen Shale Shaker

Removes drilled solids larger than 177-260 microns. Small amounts of colloidal barite may be removed with drilled solids.

Returns smaller solids to active mud system.

Operates on entire circulating volume.

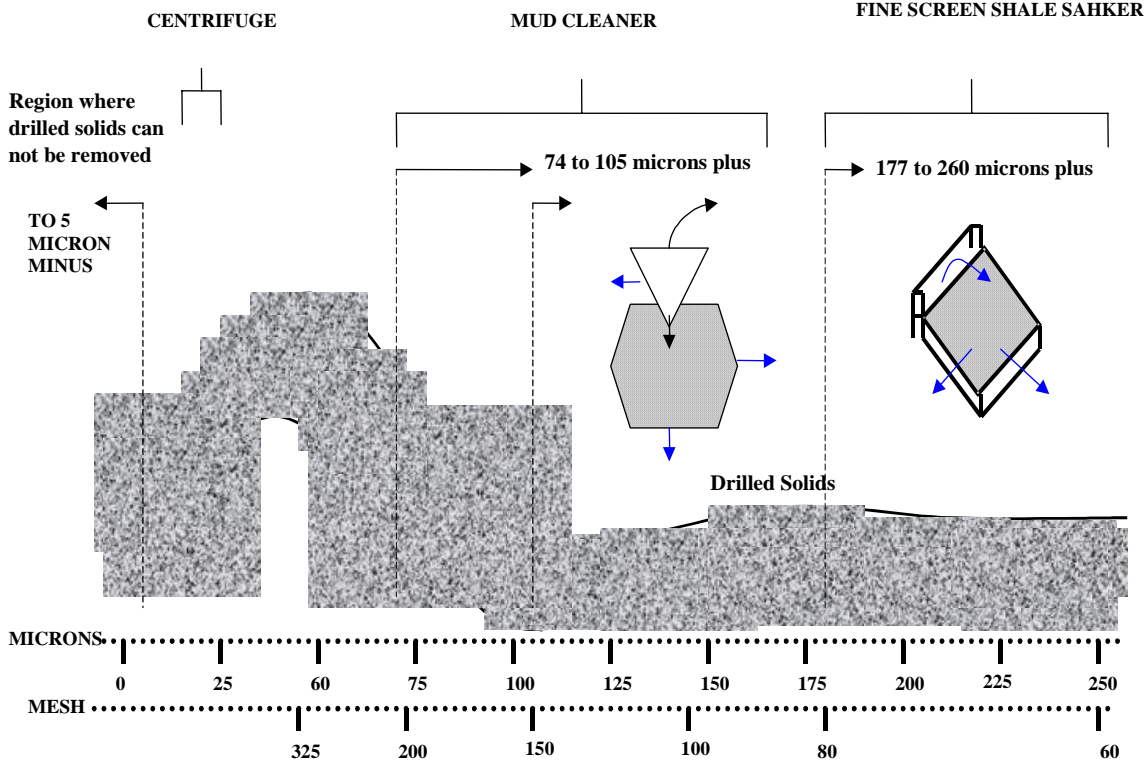

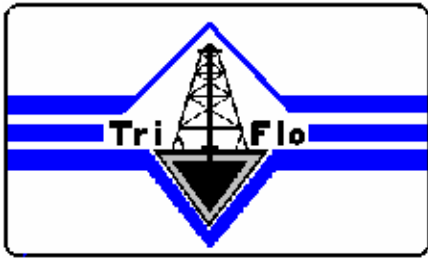

Tri-Flo Int'l, Inc.

P.O. Box 2626, Conroe, Texas 77305
 Bus: (936) 856-8551 Fax: (936) 856-5668

LOW VOLTAGE WIRING

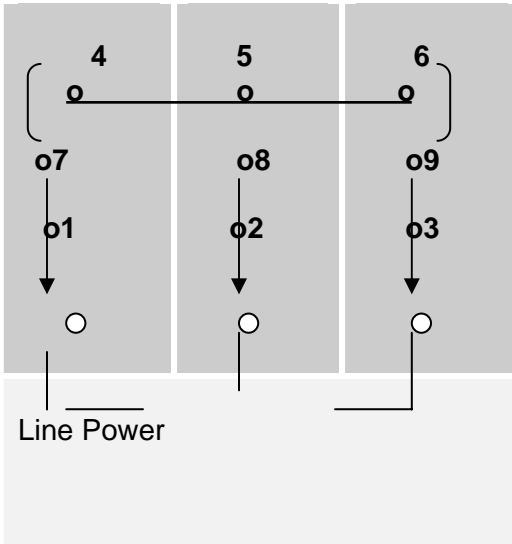

Motor leads 4-5-6 together tape
 Motor leads 7-1 power lead 1 - tape
 Motor leads 8-2 power lead 2 - tape
 Motor leads 9-3 power lead 3 - tape

Note: The low voltage heater is a H33, parte No. 01-00-043 If it is necessary to change from high voltage (460 V.A.C.) to low voltage (230 V.A.C.), the heater must be changed.

HIGH VOLTAGE WIRING

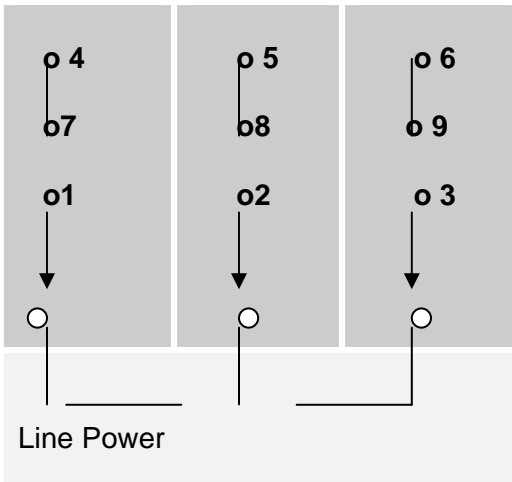

Motor lead 4-7 tape
 Motor lead 5-8 tape
 Motor lead 6-9 tape
 Motor lead 1 - to power lead 1 - tape
 Motor lead 2 - to power lead 2 - tape
 Motor lead 3 - to power lead 3 - tape

Note: High Voltage heater is a H26. TRI-FLO Part No. 01-00-041. If it is necessary to change from low voltage (230 V.A.C.) to High voltage (460 V.A.C.), the heater must be changed.

NOTE: (If the motor rotates in wrong direction reverse any two of the power leads.)

NOTE: IF THE MOTOR JUNCTION BOX IS REWIRED OR CHANGED IT MUST BE PACKED WITH FOAM RUBBER TO PREVENT THE WIRES FROM RUBBING TOGETHER WHEN THE SHAKER IS VIBRATING.

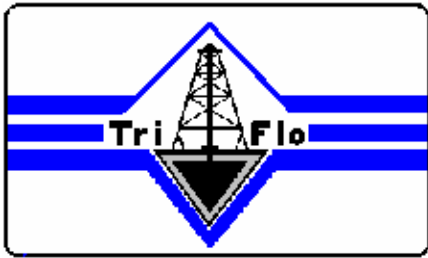

Tri-Flo Int'l, Inc.
 P.O. Box 2626, Conroe, Texas 77305
 Bus: (936) 856-8551 Fax: (936) 856-5668

TENSION PLATE AND SCREEN ASSEMBLY

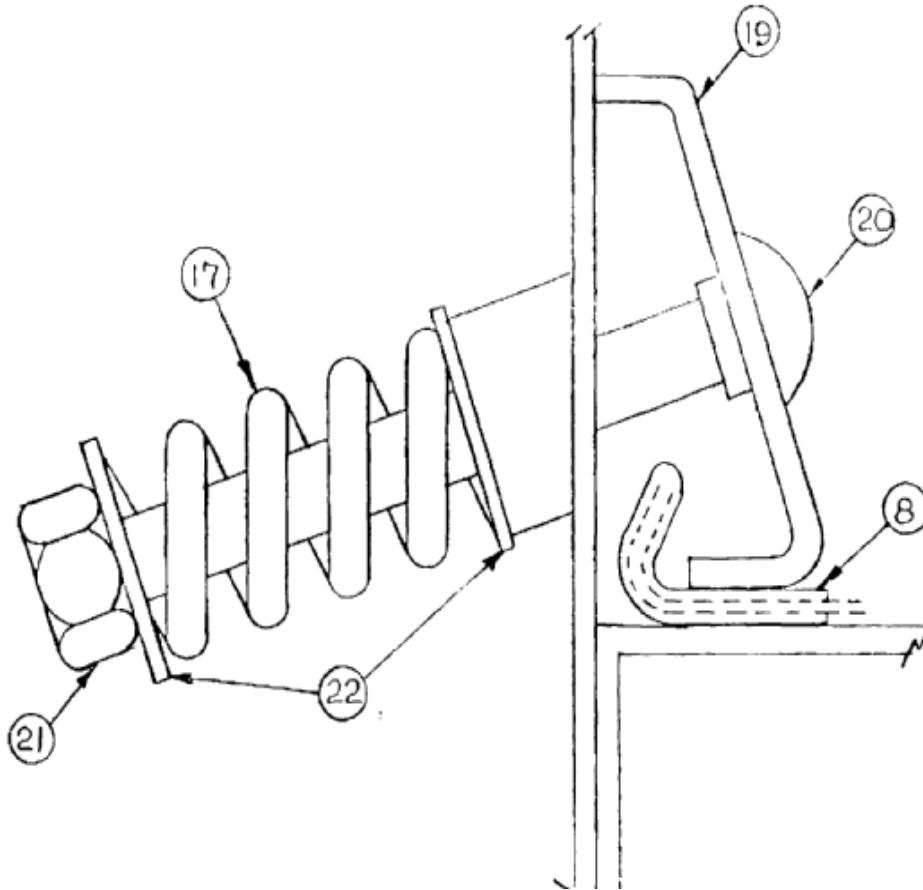

Part

Tension Bolt Assembly
 (includes bolt, nut spring, & 2 washers)
 Tension Bolt (Item 20)
 Tension Spring (Item 17)
 Tension Lock Nut (Item 21)
 Tension Washer (Item 22)
 Tension Rail Plate

Tri-Flo Part No.

03-00-006

 04-00-107
 05-00-350
 04-00-150
 04-00-177
 03-00-007

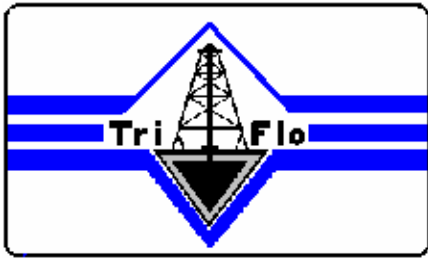

Tri-Flo Int'l, Inc.

P.O. Box 2626, Conroe, Texas 77305
 Bus: (936) 856-8551 Fax: (936) 856-5668

COMMON OILFIELD SHAKER SCREENS

Mesh	Wire Diameter	Opening Inches	Opening Microns	Open Area
8x8	.028	.097	2464	60.2
10x10	.025	.075	1905	56.3
12x12	.023	.060	1524	51.8
14x14	.020	.051	1295	51.0
16x16	.018	.0445	1130	50.7
18x18	.018	.0376	955	45.8
20x20	.017	.033	838	43.6
8x20	.032/.020	.093/.030	2362/762	45.7
20x30	.015	.035/.0183	889/465	39.5
30x30	.012	.0213	541	40.8
30x40	.010	.0233/.015	592/381	42.5
40x36	.010	.015/.0178	381/452	40.5
40x40	.010	.015	381	36.0
50x40	.0085	.0115/.0165	292/419	38.3
50x50	.009	.011	279	30.3
60x40	.009	.0077/.016	200/406	31.1
60x60	.0075	.0092	234	30.5
70x30	.0075	.007/.026	178/660	40.3
80x80	.0055	.007	178	31.4
100x100	.0045	.0055	140	30.3
120x120	.0037	.0046	117	30.9
150x150	.0026	.0041	104	37.4
160x160	.0025	.0038	97	37.64
200x200	.0021	.0029	74	33.60

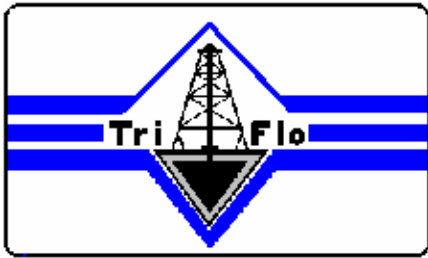

Tri-Flo Int'l, Inc.
 P.O. Box 2626, Conroe, Texas 77305
 Bus: (936) 856-8551 Fax: (936) 856-5668

DIMENSIONS FOR SINGLE SHAKER

- | | | |
|------------|------------|-------------|
| A — 8' 2" | C — 2' 6½" | E — 3' 10"@ |
| B — 3' 1½" | D — 1' 4" | F — 5' 5½" |

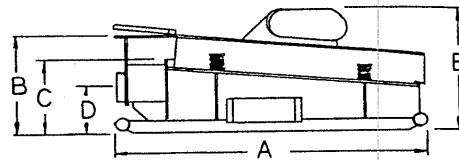
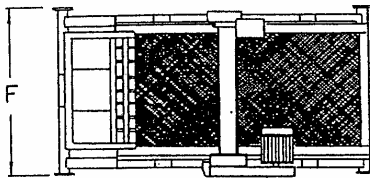

EACH SHAKER:

Powered by: 3 hp 230/460 volt
 3 phase 60 hz. motor
 Operating speed: 1750 RPM

Explosion proof motor & starter.
 10" Feed Manifold with by pass to mud tanks.
 Weight: 2575 lbs.

DIMENSIONS FOR DUAL SHAKER

- | | | | |
|------------|-------------|------------|------------|
| A — 6' 5" | D — 1' 6½" | G — 5' 3" | I — 2' 0½" |
| B — 3' 3¾" | E — 4' 1½"@ | H — 13' 0" | J — 8' 0" |
| C — 2' 8" | | | |

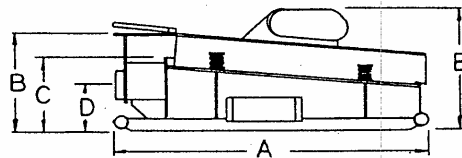
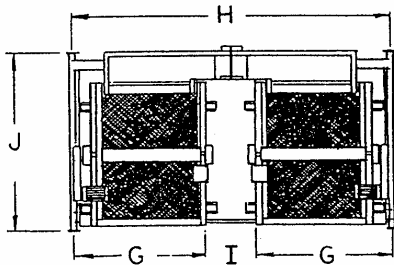

EACH SHAKER:

Powered by: 3 hp 230/460 volt
 3 phase 60 hz. motor
 Operating speed: 1750 RPM

Explosion proof motor & starter.
 10" Feed Manifold with by pass to mud tanks.
 Weight: 7280 lbs.

Call Us

We will be most happy to further explain the advantages of our equipment or discuss any other needs you might have. Expertise in solids control, pressure control and rig instrumentation is what Tri-Flo is all about.



Tri-Flo
 on the job
 when and where you need us.

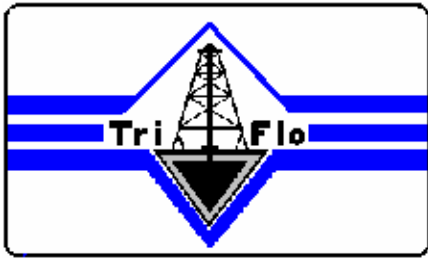

Tri-Flo Int'l, Inc.

P.O. Box 2626, Conroe, Texas 77305
Bus: (936) 856-8551 Fax: (936) 856-5668

NOTES