

Tri-Flo Int'l, Inc.
P.O. Box 2626, Conroe, Texas 77305
Bus: (936) 856-8551 Fax: (936) 856-5668

Service & Operating Manual

TRI-FLO PIT PUMP

2", 3", 4" & 6"



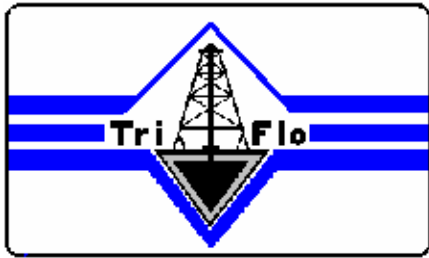

Tri-Flo Int'l, Inc.

**P.O. Box 2626, Conroe, Texas 77305
Bus: (936) 856-8551 Fax: (936) 856-5668**

The TFI pit pump is a high volume low-pressure centrifugal pump with the suction intake on top. This enables the pump to be placed on the pit bottom without obstructing suction. The submerged shaft bearing is protected by packing gland with four lip seals that are greased lubricated for long life of bearing and shaft.



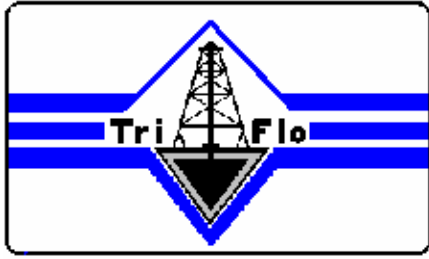

Tri-Flo Int'l, Inc.

**P.O. Box 2626, Conroe, Texas 77305
Bus: (936) 856-8551 Fax: (936) 856-5668**

ASSEMBLY PROCEDURE (PIT PUMP)

1. Clean all sand and loose rust from shaft housing
2. Install wear plate in impeller housing.
3. Insert shaft in housing until thread end is about two inches out.
4. Install bearing, o-ring, and bearing cartridge on shaft. Slide shaft thru bearing and cartridge until thread end of shaft is protruding out of impeller case about two inches.
5. Install impeller, key, washer, and lock nut, tighten securely.
6. Adjust shaft and impeller between 1/16" – 1/8" clearance between impeller and wear plate, and outer race of bearing just touching shaft housing. Carefully move shaft and bearing back into its proper location.
7. Install bearing on motor end of shaft leaving bolts loose.
8. Slide cartridge over bearing making sure the o-ring is in place, and tighten bolts securely on both bearings.
9. Recheck impeller clearance.
10. Tighten down the bearing at the motor end, and lock the shaft down using the setscrew in the bearing.
11. Install coupling and motor.
12. Install pump case cover, shaft packing, and gland.

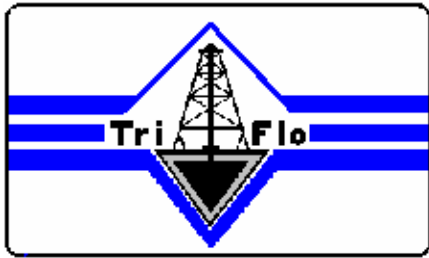

Tri-Flo Int'l, Inc.

P.O. Box 2626, Conroe, Texas 77305
Bus: (936) 856-8551 Fax: (936) 856-5668

PIT PUMP SHAFT PACKING INSTALLATION

1. Place lip seal ring in gland with seal lip facing out.
2. Place lantern ring in gland
3. Place three more lip seals in gland with seal facing out.
4. Install two pieces gland around shaft and tighten only snug with gland bolts.
(NOTE) Packing must be greased every eight hours.

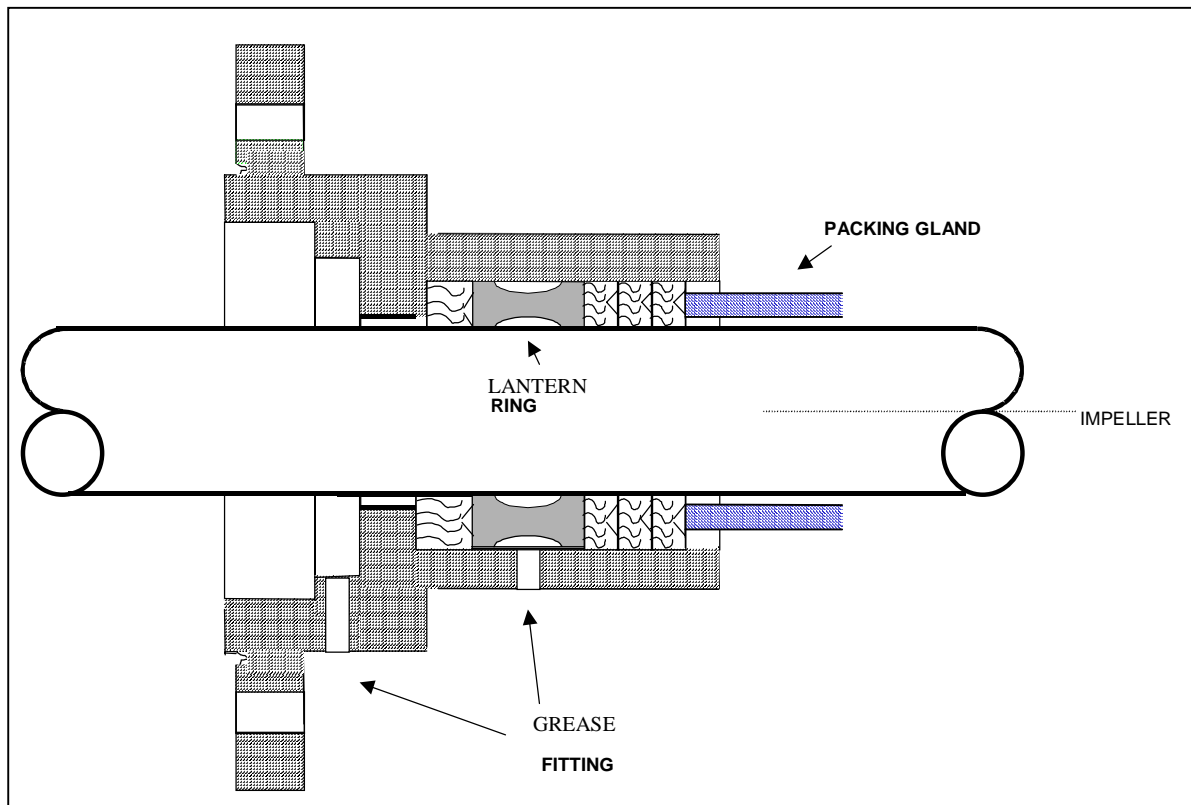

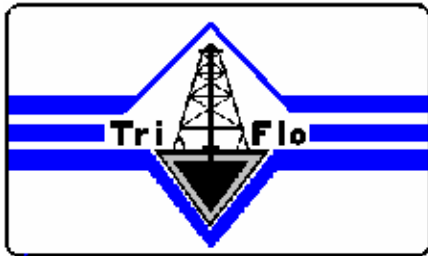

Tri-Flo Int'l, Inc.

P.O. Box 2626, Conroe, Texas 77305
 Bus: (936) 856-8551 Fax: (936) 856-5668

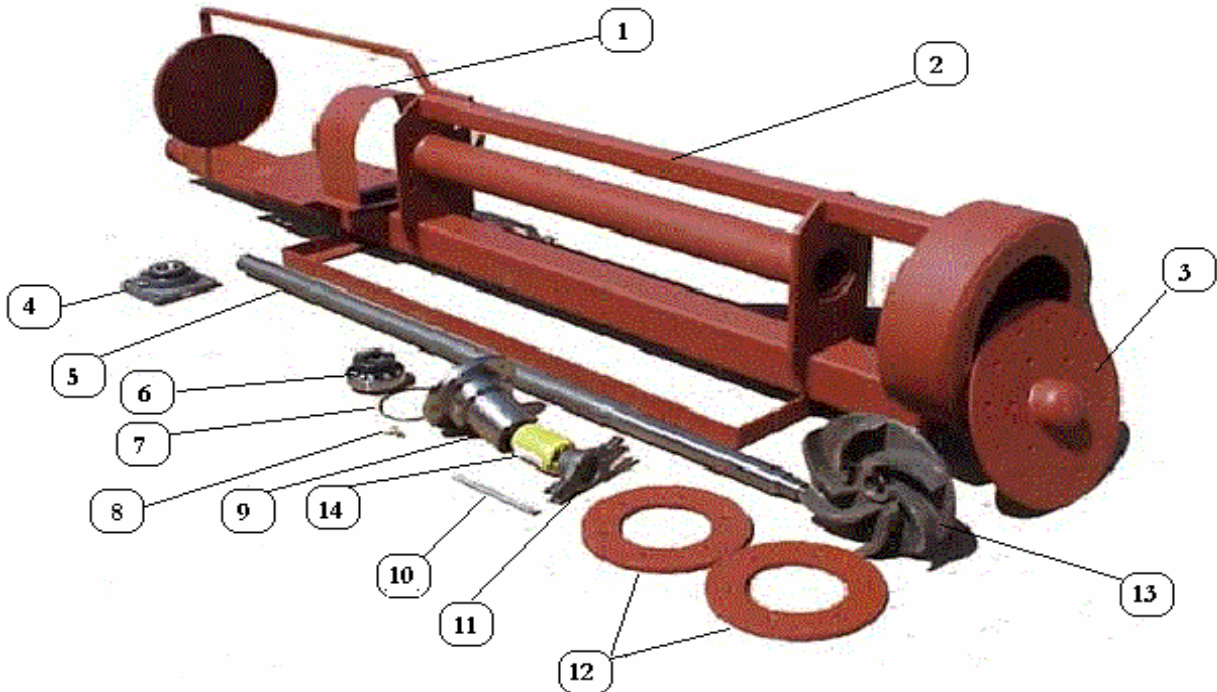

2" PUMP PARTS

ITEM #	PART #	QTY	DESCRIPTION
1	02-00-228	1	PUMP COUPLING GUARD
2	N/A	1	PUMP FRAME
3	02-00-223	1	CASE COVER BOTTOM
4	05-00-058	1	FLANGED PILLOW BLOCK
5	02-00-272	1	PUMP SHAFT
6	05-00-047	1	BALL BEARING
7	03-00-659	1	O-RING
8	05-00-186	2	GREASE FITTING
9	02-00-271	1	BEARING CARTRIDGE
10	04-00-240	2	ALL THREAD 3/8"
11	05-00-295	1	PACKING GLAND
12	02-00-222	2	WEAR RING
13	02-00-070	1	7.5" IMPELLER
14	05-00-294	1	PACKING ASSEMBLY
(NOT SHOWN)	00-00-028	1	COUPLING ELEMENT
(NOT SHOWN)	01-00-134	1	MOTOR 5 hp 1800 RPM
(NOT SHOWN)	00-00-843	2	GREASE HOSE

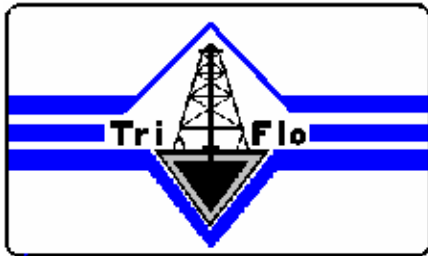

Tri-Flo Int'l, Inc.

P.O. Box 2626, Conroe, Texas 77305
 Bus: (936) 856-8551 Fax: (936) 856-5668

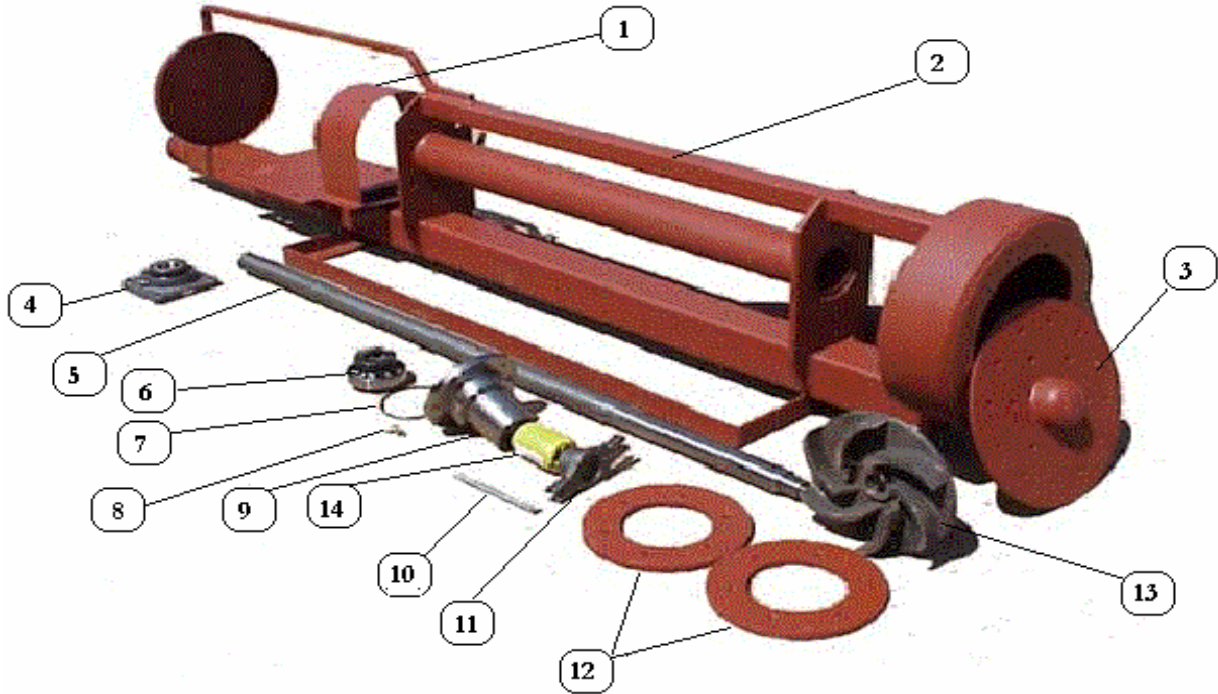

3" PUMP PARTS

ITEM #	PART #	QTY	DESCRIPTION
1	02-00-238	1	PUMP COUPLING GUARD
2	N/A	1	PUMP FRAME
3	02-00-233	1	CASE COVER BOTTOM
4	05-00-011	1	FLANGED PILLOW BLOCK
5	02-00-273	1	PUMP SHAFT
6	02-00-044	1	CAMLOCK BALL BEARING
7	03-00-629	1	O-RING
8	05-00-186	2	GREASE FITTING
9	02-00-270	1	BEARING CARTRIDGE
10	04-00-240	2	ALL THREAD 3/8"
11	05-00-299	1	PACKING GLAND
12	02-00-232	2	WEAR RING
13	02-00-073	1	10" IMPELLER
14	05-00-296	1	PACKING ASSEMBLY
(NOT SHOWN)	00-00-087	1	COUPLING ELEMENT
(NOT SHOWN)	01-00-147	1	MOTOR 7.5 hp 1200 RPM
(NOT SHOWN)	00-00-843	2	GREASE HOSE
(OPTIONAL)	01-00-133	1	MOTOR 15 hp 1800 RPM
(OPTIONAL)	02-00-094	1	9" IMPELLER (Mandatory with 15 hp Motor)

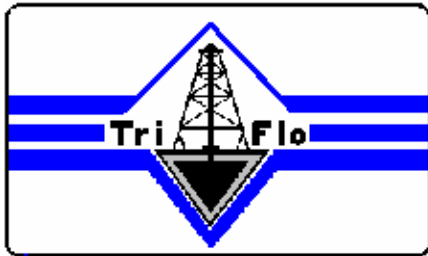

Tri-Flo Int'l, Inc.

P.O. Box 2626, Conroe, Texas 77305
 Bus: (936) 856-8551 Fax: (936) 856-5668

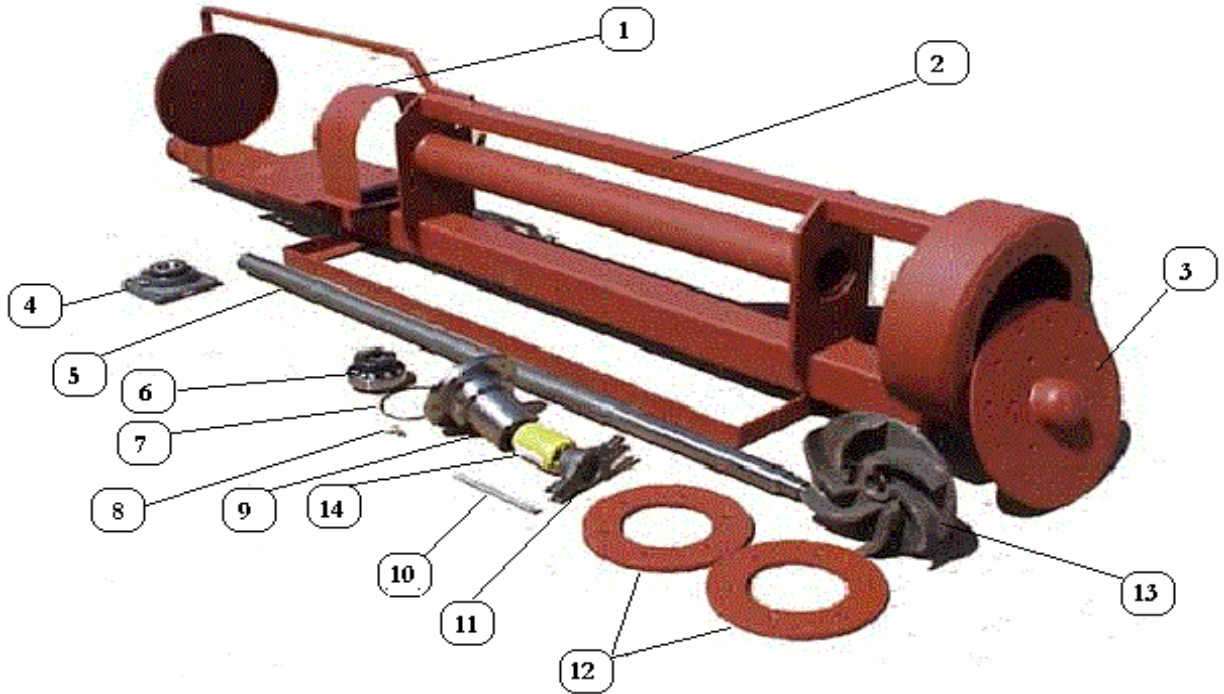

4" PUMP PARTS

ITEM #	PART #	QTY	DESCRIPTION
1	02-00-238	1	PUMP COUPLING GUARD
2	N/A	1	PUMP FRAME
3	02-00-243	1	CASE COVER BOTTOM
4	05-00-011	1	FLANGED PILLOW BLOCK
5	02-00-274	1	PUMP SHAFT
6	02-00-044	1	CAMLOCK BALL BEARING
7	03-00-629	1	O-RING
8	05-00-186	2	GREASE FITTING
9	02-00-270	1	BEARING CARTRIDGE
10	04-00-240	2	ALL THREAD 3/8"
11	05-00-299	1	PACKING GLAND
12	02-00-242	2	WEAR RING
13	02-00-058	1	9.5" IMPELLER
14	05-00-296	1	PACKING ASSEMBLY
(NOT SHOWN)	00-00-087	1	COUPLING ELEMENT
(NOT SHOWN)	01-00-131	1	MOTOR 10 hp 1200 RPM
(NOT SHOWN)	00-00-843	2	GREASE HOSE
(OPTIONAL)	01-00-151	1	MOTOR 20hp 1800 RPM
(OPTIONAL)	02-00-095	1	9" IMPELLER (Mandatory with 20 hp Motor)

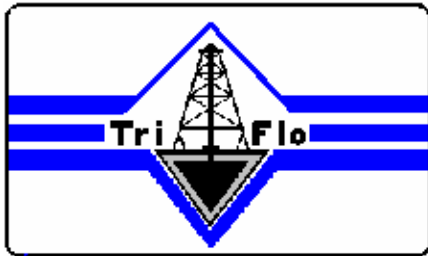

Tri-Flo Int'l, Inc.

P.O. Box 2626, Conroe, Texas 77305
 Bus: (936) 856-8551 Fax: (936) 856-5668

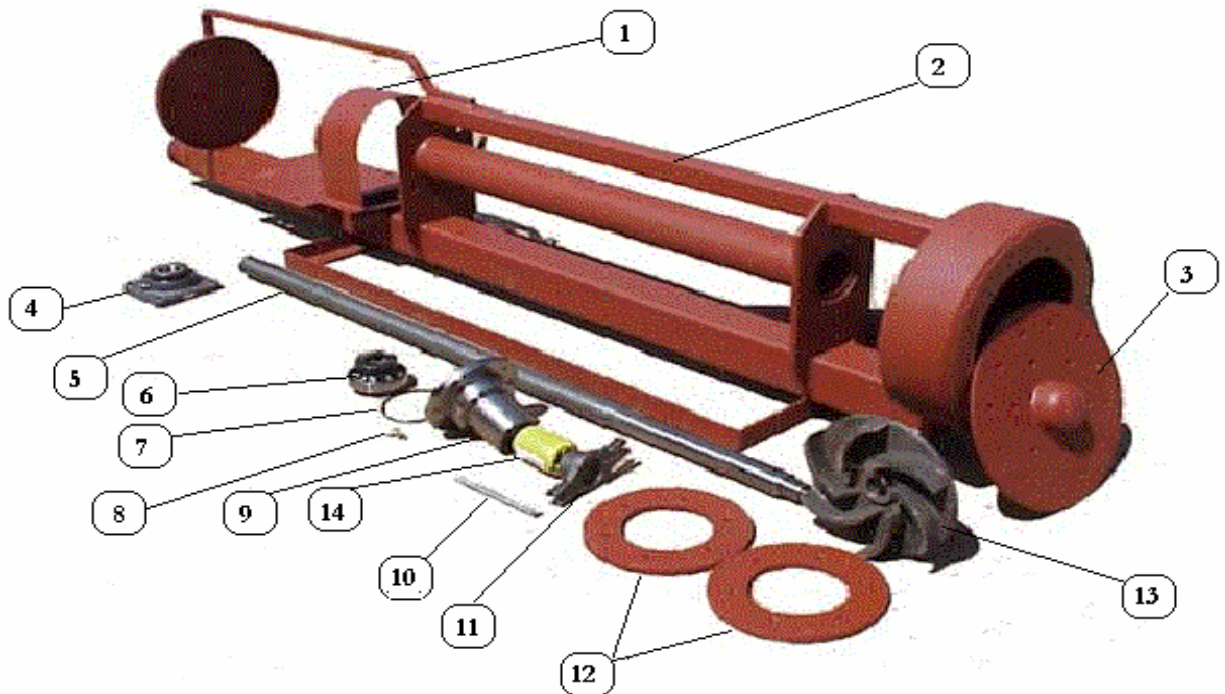

6" PUMP PARTS

ITEM #	PART #	QTY	DESCRIPTION
1	02-00-238	1	PUMP COUPLING GUARD
2	N/A	1	PUMP FRAME
3	02-00-263	1	CASE COVER BOTTOM
4	05-00-011	1	FLANGED PILLOW BLOCK
5	02-00-274	1	PUMP SHAFT
6	02-00-044	1	CAMLOCK BALL BEARING
7	03-00-629	1	O-RING
8	05-00-186	2	GREASE FITTING
9	02-00-270	1	BEARING CARTRIDGE
10	04-00-240	2	ALL THREAD 3/8"
11	05-00-299	1	PACKING GLAND
12	02-00-262	2	WEAR RING
13	02-00-053	1	9" IMPELLER
14	05-00-296	1	PACKING ASSEMBLY
(NOT SHOWN)	00-00-662	1	COUPLING ELEMENT
(NOT SHOWN)	01-00-122	1	MOTOR 30 hp 1800 RPM
(NOT SHOWN)	00-00-843	2	GREASE HOSE

NOTES